

INSTRUCTION MANUAL
REGULATED DC POWER SUPPLY
PAK 2kW SERIES

APPLICABLE MODELS

PAK10-200T

PAK20-100T

KIKUSUI ELECTRONICS CORPORATION

(KIKUSUI PART NO. Z1-725-320)

874769

Power Requirements of this Product

Power requirements of this product have been changed and the relevant sections of the Operation Manual should be revised accordingly.

(Revision should be applied to items indicated by a check mark)

Input voltage

The input voltage of this product is _____ VAC,
and the voltage range is _____ to _____ VAC. Use the product within this range only.

Input fuse

The rating of this product's input fuse is _____ A, _____ VAC, and _____.

WARNING

- To avoid electrical shock, always disconnect the AC power cable or turn off the switch on the switchboard before attempting to check or replace the fuse.
- Use a fuse element having a shape, rating, and characteristics suitable for this product. The use of a fuse with a different rating or one that short circuits the fuse holder may result in fire, electric shock, or irreparable damage.

AC power cable

The product is provided with AC power cables described below. If the cable has no power plug, attach a power plug or crimp-style terminals to the cable in accordance with the wire colors specified in the drawing.

WARNING

- The attachment of a power plug or crimp-style terminals must be carried out by qualified personnel.



TABLE OF CONTENTS

	<u>PAGE</u>
1. GENERAL -----	1 - 1
1.1 Specifications -----	1 - 3
2. OPERATION METHOD -----	2 - 1
2.1 General Precautions Before Use -----	2 - 1
2.2 AC Line Voltage Change -----	2 - 8
2.3 Panel Description -----	2 - 10
2.4 Operation Method -----	2 - 18
2.5 Contact Signals -----	2 - 23
3. PROTECTIVE CIRCUITS -----	3 - 1
3.1 Background -----	3 - 1
3.2 Protective Circuits -----	3 - 1
3.3 Operation Method of OVP (Overvoltage Protector) -----	3 - 3
4. APPLICATIONS -----	4 - 1
4.1 To Disable the OUTPUT Switch -----	4 - 1
4.2 ON/OFF Control of Output -----	4 - 2
4.3 Remote Control of POWER Switch -----	4 - 3
4.4 To Select OVP Mode -----	4 - 4
4.5 To Select Crowbar (High Speed Thyristor OVP) Mode -----	4 - 5
4.6 Remote Sensing -----	4 - 6
4.7 Remote Control of Output Voltage -----	4 - 8
4.7.1 Control of Output Voltage with External Voltage Signal -----	4 - 8
4.7.2 Linear Control of Output Voltage with External Resistance Signal -----	4 - 10
4.7.3 Fail-safe Control of Output Voltage with External Resistance Signal -----	4 - 13
4.8 Remote Control of Output Current -----	4 - 15
4.8.1 Control of Output Current with External Voltage Signal -----	4 - 15

87 9 29

87 9 29

	<u>PAGE</u>
4.8.2 Linear Control of Output Current with External Resistance Signal -----	4 - 17
4.8.3 Fail-safe Control of Output Current with External Resistance Signal -----	4 - 20
4.9 Series or Parallel Operation -----	4 - 22
4.10 Master-slave Parallel Operation -----	4 - 24
4.11 Master-slave Series Operation -----	4 - 30
4.12 Constant-current Charge/Discharge -----	4 - 33
 5. MAINTENANCE -----	 5 - 1
5.1 Inspection -----	5 - 1
5.2 Adjustment and Calibration -----	5 - 2

65 6 1/3

874 7722

1. GENERAL

The PAK Series Regulated DC Power Supply is a constant-voltage constant-current switching regulator with variable output. The PAK Series is compact and light - its weight and sizes are only several tenths of those of a conventional phase-controlled type of power supply. The ripple voltages are small and response to transients are excellent. Other features of the PAK Series can be summarized as follows:

- (1) The high-speed large-capacity switching circuit is comprised of double forward converters, thereby eliminating magnetic polarization of the switching transformer which could be caused by aging and thereby providing a stable output.
- (2) A heat pipe type of radiation system is employed, thereby preventing degradation of reliability or maintainability which could be caused by dust collected when the power supply is operated for a long period time.
- (3) A front air intake system is employed, thereby allowing high density packing for rackmounting.
- (4) A GP-IB board (option PAK-E2) is available. This board allows settings of voltage and current and OVP, feedback of output, and monitoring of the statuses of the power supply, thereby allowing you to use the power supply as a component of a computer-controlled automatic system.
- (5) A remote/local selector switch is provided. This switch allows you to locally control the power supply with its front panel controls, to control the power supply remotely via the rear terminal block, or to control the power supply through the built-in GP-IB board (option PAK-E2).

The output voltage and current are finely adjustable with respective 10-turn potentiometers. They can be fixed or semi-fixed with guard caps to protect against inadvertent change or unauthorized change.

The PAK Series is incorporated with the various protective features such as automatic C.V/C.C transfer, an overvoltage protector whose voltage can be set from the front panel, an input overvoltage protector, an overcurrent protector, a rush current protector, an output overcurrent protector, an overheat protector which trips by detecting the semiconductor heat sink temperature, and a thermal fuse on the subtransformer.

A high-speed overvoltage protector is available as an optional feature (option PAK-P). This feature is especially effective for such loads as semiconductors whose allowable overvoltage is small and which can be damaged even with a slight overvoltage (which can be caused also by inadvertent handling).

PRECAUTIONS: BE SURE TO READ THIS MANUAL BEFORE STARTING OPERATING THE POWER SUPPLY.

1.1 Specifications

		Models	
Input		PAK 10-200T	PAK 20-100T
AC input		3-Phase 200V/240V AC $\pm 10\%$, 50/60Hz Selectable by internal switch *7	
Input current	200V AC, rated load (typical)	11.5 A rms	11.0 A rms
Apparent power	200V AC, rated load (typical)	4.0 kVA	3.8 kVA
Output			
Output voltage range	10 turns	0 ~ 10 V	0 ~ 20 V
Voltage resolution (typical)		2 mV	4 mV
Output current range	10 turns	0 ~ 200 A	0 ~ 100 A
Current resolution (typical)		40 mA	20 mA
Efficiency	200V AC rated load (typical)	81%	82%
Power factor	200V AC rated load (typical)	0.63	0.65
Constant-voltage characteristics			
Regulation			
Source effect (line regulation)	(For $\pm 10\%$ change of line voltage) *1, 2	0.05% + 5 mV	
Load effect (load regulation)	(For 0~100% change of output current)	0.1% + 5 mV	
Ripple and noise			
Effectiv value (5Hz ~ 1kHz)	*2	20 mV rms	
Peak-to-peak value (DC ~ 10kHz)(typical) *3		200 mV p-p	
Transient response 10%~100% change (typical) *4		2 mSec	
Temperature coefficient (typical)		100 ppm/°C	
Rise time of output voltage.No load/Full load (typical)		approx 150/150 mSec	
Fall time of output voltage.No load/Fall load (typical)		approx 2000/20 mSec	
Remote control Voltage/Output voltage		approx 10V/10V approx 10V/20V	
Remote control Resistance/Output voltage		approx 10k Ω /10V approx 10k Ω /20V	
Constant-current characteristics			
Regulation			
Source effect (line regulation)	(For $\pm 10\%$ change of line voltage) *2	0.1% + 100 mA	
Load effect (load regulation)	(For 0~100% change of output voltage)	0.1% + 100 mA	
Ripple and noise Effective value (5Hz ~ 1 MHz) *2		0.5% + 750 mA	0.5% + 500 mA
Remote control Voltage/Output current		approx 10V/200A	approx 10V/100A
Remote control Resistance/Output current		approx 10k Ω /200A	approx 10k Ω /100A

	Models	PAK 10-200T	PAK 20-100T
Operating ambient temperature range		0 ~ 40°C (32 ~ 104°F)	
Operating ambient humidity range		30 ~ 80% RH	
Storage temperature range		-20 ~ 70°C (-4 ~ 158°F)	
Storage temperature range		20 ~ 80% RH	
Cooling method		Forced air cooling with fan	
Output signals			
Constant-voltage operation indication	Contact output	Contact made when in C.V mode	
Constant-current operation indication	Contact output	Contact made when in C.C mode	
Power ON - OFF/Alarm indication	Contact output	Made and broken	
Readout		3- 1/2 digits, green LED	
Voltmeter	Full scale	10.00 V	20.0 V
	Accuracy (20°C±10°C)	±0.1% rdg ±1 digit	
Ammeter	Full scale	200 A	100.0 A
	Ammeter (20°C±10°C)	±0.5% rdg ±2 digits	
Measuring system and sampling rate		Integration system, sampling rate 3 times/sec	
Over-range display		Unilluminating three least-significant digits	
Constant-voltage mode indication		C.V : With green LED	
Constant-current mode indication		C.C : With red LED	
Protections			
Overvoltage protection	Voltage setting range *8	1 ~ 13 V	1 ~ 25 V
Overvoltage protection	Operation	Stop oscillation and cuts out input switch	
Overcurrent protection		Trip at 110% of rated output current	
Overtemperature protection		85°C (185°F)	
Input overvoltage protection		Cuts out input switch	
Input overcurrent protection		Cuts out input switch	
Rush current suppression circuit	*5	30 A at 200V AC	
Input fuse rating			
	Main circuit 250V AC	15 A	15 A
	Auxiliary circuit 250V AC	2 A	2 A
Thermal fuse rating	At auxiliary transformer	Blows out at 135°C (275°F)	
Phase dropout protector		Stops oscillation	

874777

Models		PAK 10-200T	PAK 20-100T
Polarity of output voltage		Positive or negative grounded	
Isolation from ground		± 250V DC	
Withstanding voltage			
Between input and output, input and ground		1.5kV AC, 1 minute	
Insulation resistance	*6		
Between chassis and input		500V DC 30MΩ or more	
Between chassis and output		500V DC 20MΩ or more	
Dimensions			
Maximum dimensions		430 W × 146 H × 430 D mm (16.93 W × 5.75 H × 16.93 D in.)	
		450 W × 161 H × 505 D mm (17.72 W × 6.34 H × 19.88 D in.)	
Rack mounting			
Bracket for JIS rack (mm-unit rack)		BH 3 T M - 1	
Bracket for EIA rack (19 in.)		BH 4 A T - 1	
Weight		approx 21 kg (46 lbs)	approx 21 kg (46 lbs)
Accessories (in carton)			
Instruction manual		1 copy	
Input line fuse (spare)			
15 φ × 50L		15 A (300V AC)	3 ea
6.4 φ × 32L		2 A (250V AC)	1 ea
Guard cap 1 set, DIN connector 1 ea, Air filter 1 ea			
Input cord			
seal (For AC 240V 2 sh, for air filter 1 sh)			
		4-core type (3.5 mm ²), approx. 3m	
			1 set

NOTES

- * 1 Measured using the sensing terminals.
- * 2 Measured with the positive or negative output terminal grounded.
- * 3 Measuring method is as shown in Figure 1-1.
- * 4 Load effect recovery time within 0.5% + 50mV of the setting output voltage.
(for 10% to 100% change of output current)
- * 5 Allow one second or more before turning on the switch which has tripped.
- * 6 Measured in room at 70% RH or less
- * 7 All models are available with optional input 3-phase 220V AC ± 10%.
- * 8 Presettable voltage of PAK-P O.V.P (option) is 3V or over.

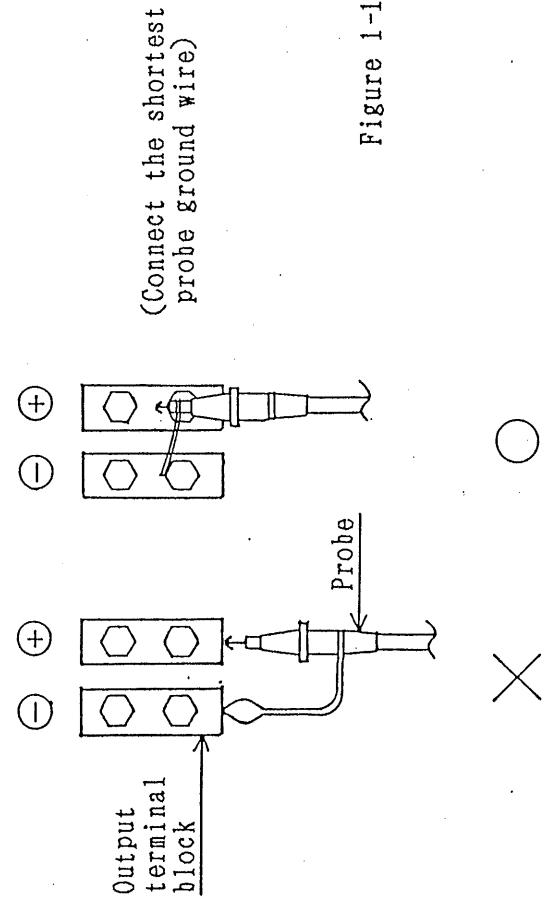
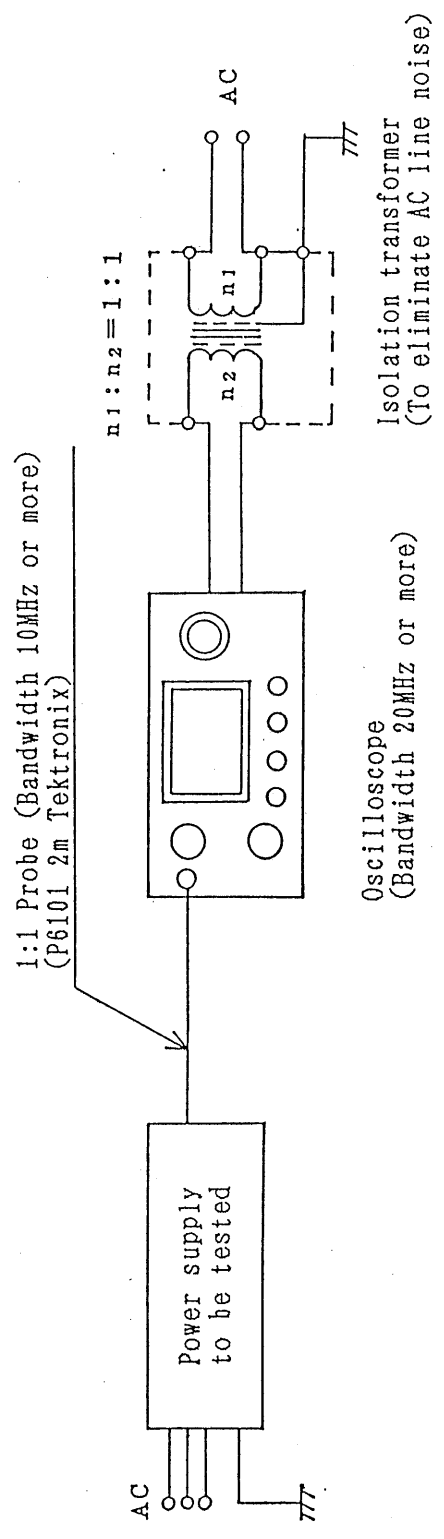

Figure 1-1. Setup for Measurement of Ripple Voltage (Peak-to-peak)

87479

Current Consumption Chart

PAK 10-200T

AC 200V 3 ϕ 50Hz

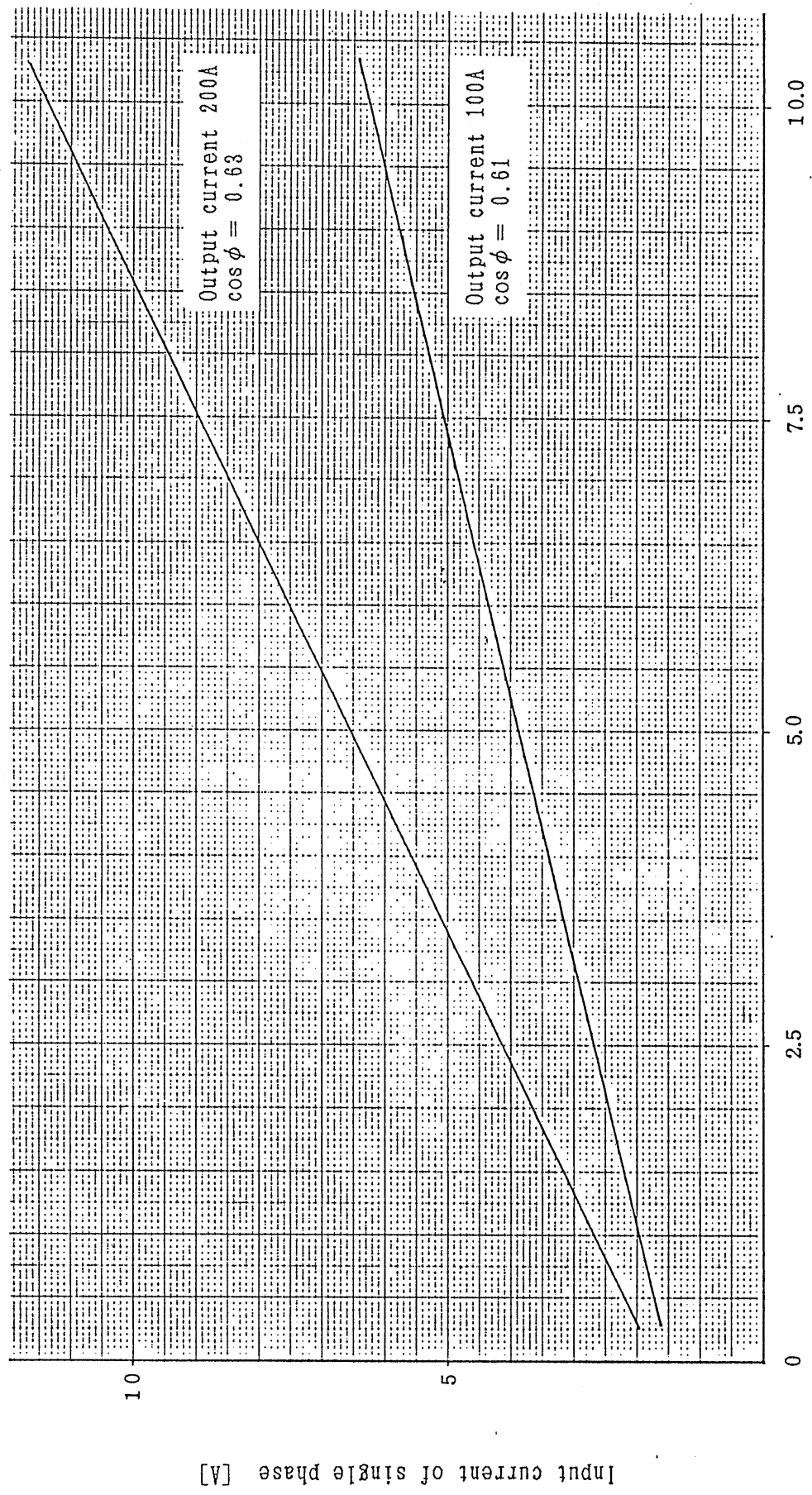

874780

Current Consumption Chart

PAK 20-100T

AC 200V 3 ϕ 50Hz

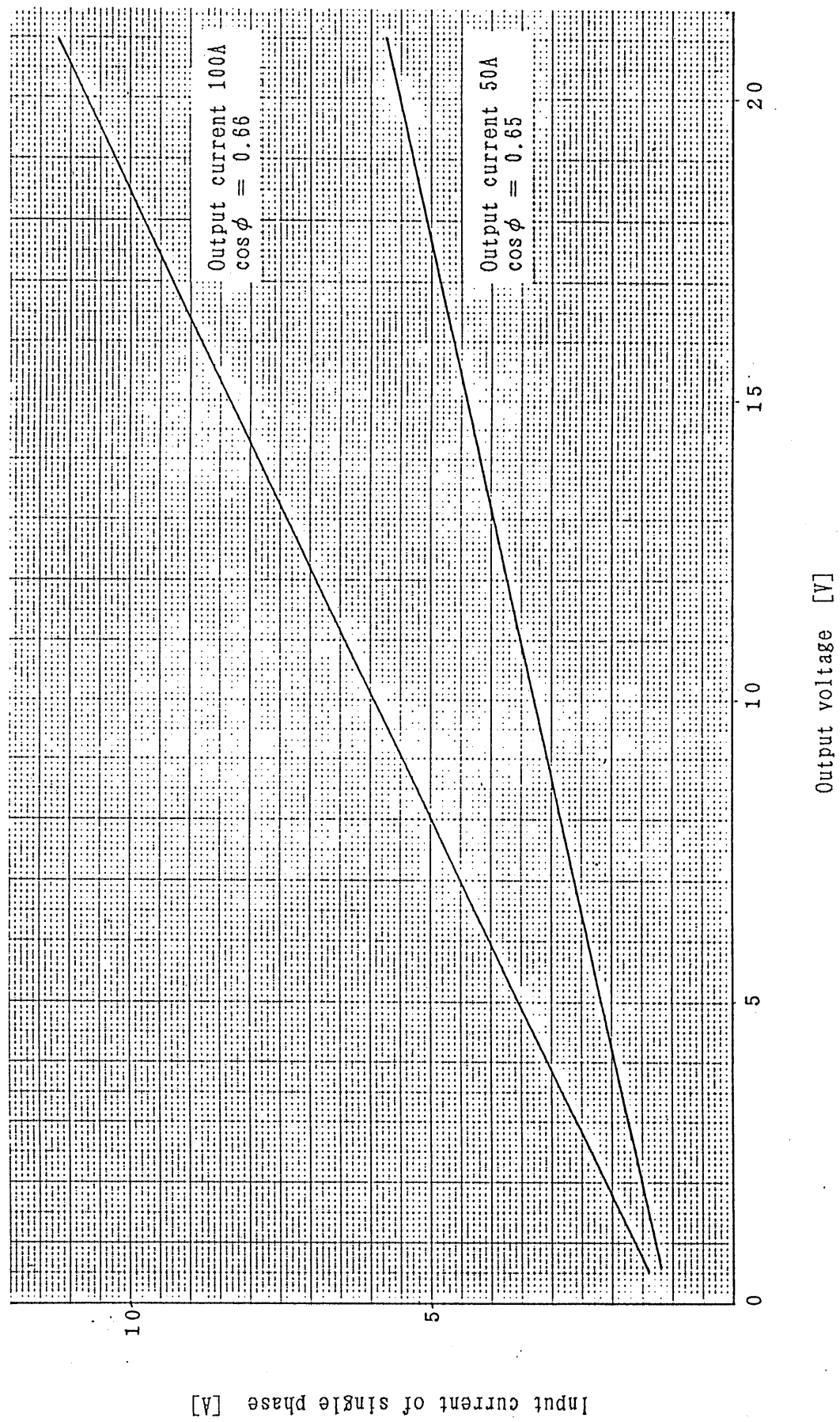

2. OPERATION METHOD

2.1 General Precautions Befor Use

2.1.1 Installation

- o The allowable or inhibited mounting attitudes of the power supply are as shown in Figure 2-1. Install it in the attitude of [A] or [B]. Don not install it in the attitude that the handle is positioned lower than the horizontal level.

PRECAUTIONS: Note that, if the power supply is installed in the inhibited attitude, its overheat protector may trip and the input power switch may be cut out.

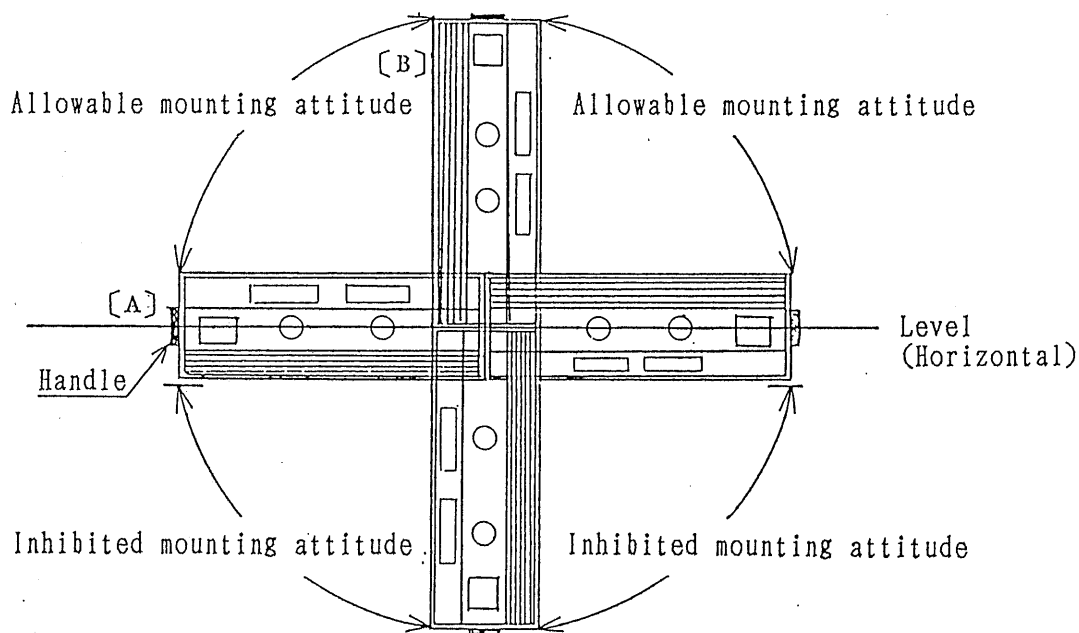

Figure 2-1

- o Avoid installing the power supply in a metal-corrosive atmosphere or a sulfuric acid mist atmosphere. When the power supply is used for a plating shop or an electrolytic formation shop, install the power supply at a location as apart as possible from the shop and remote-control the output.
- o Do not block the air intake opening of the front panel. Clean the air filter periodically.

- o Provide a clearance of 30 cm (1 foot) or more from the fan air exhaust.
- o Note that the reliability of the power supply may be degraded and troubles may be caused if it is used in a highly humid atmosphere or in a dusty area.
- o The place of installation should be reasonably free from mechanical vibration.

2.1.2 AC Line Power

- o The input AC power line must be 200 V $\pm 10\%$ (180V to 220V) or 240 V $\pm 10\%$ (216V to 264V), 48 to 62Hz 3-phase. (See Section 2.2.)
- o The input power fuses must be as follows:

Main circuit: 15 A (15 ϕ \times 50 L) 3
 Sub-circuit: 2 A (6.4 ϕ \times 32 L) 1

2.1.3 Rush Current

- o The rush current drawn by the power supply when its power switch is turned on is approximately 30 amperes (peak) or less (with 200V AC).
- o Before turning on the power supply which has been shut down, allow a period of one second or more.

2.1.4 AC Input Power Cord

- o The sectional area of the AC input power cord which accompanies the power supply is 3.5 mm². When using a cord other than the above, be sure to use a cord of sectional area 3.5 mm² or more.
- o The green wire of the cord is a ground wire. Be sure to connect this wire to a grounding line.

2.1.5 F.G (Frame Ground) and GND

- o The F.G is connected to the chassis of the power supply. The GND is connected to the ground line of the built-in line filter as shown in Figure 2-2.

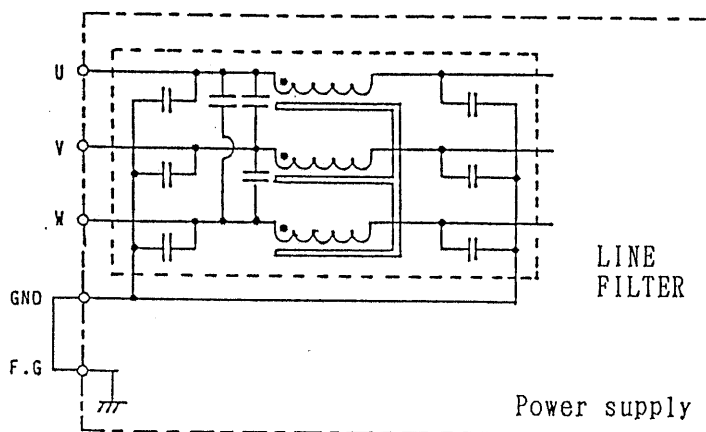

Figure 2-2

- o When using a single unit of power supply as an independent unit, short between the F.G and GND terminals.
- o When a multiple number of units are connected in parallel, the leak current from the built-in line filters increases by the number of units. If the increased leak current is not allowable, make open between the F.G and GND terminals and connect an extra line filter as shown in Figure 2-3.

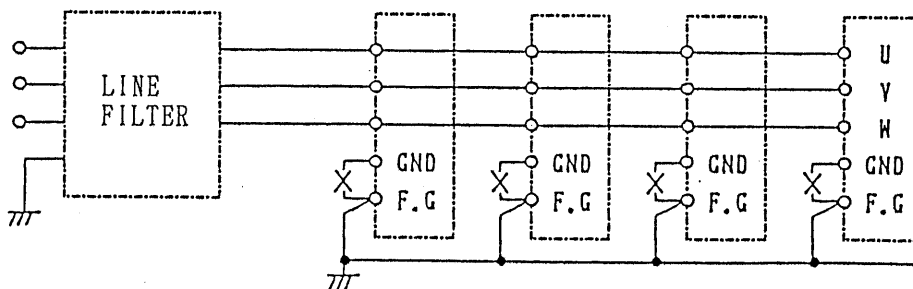

Figure 2-3

- o When power supplies are connected, the leak current increased as above may flow through the equipment frames thereby causing noise. To prevent this, make open between the F.G and GND terminals and connect the individual GND terminals to an earth with low impedance. (With this setup, the displacement current including a switching noise current can be prevented from flowing through the FG terminals.) See Figure 2-4.
- o If it is necessary to make open between the F.G and GND terminals due to the above reason, disconnect the jumper from these terminals at the input terminal block of each power supply unit. (See Figure 2-4A.)

Remarks: If it is necessary to connect an F.G for each of the units, connect it by means of the FRAME GND terminal (Ⓢ in Figure 2-18) of the output terminal block.

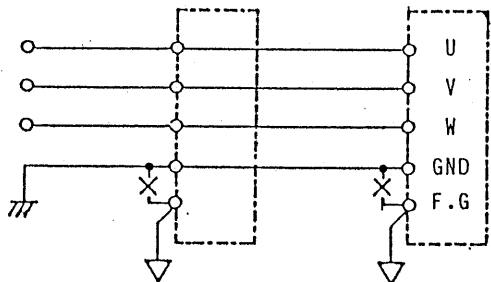

Figure 2-4

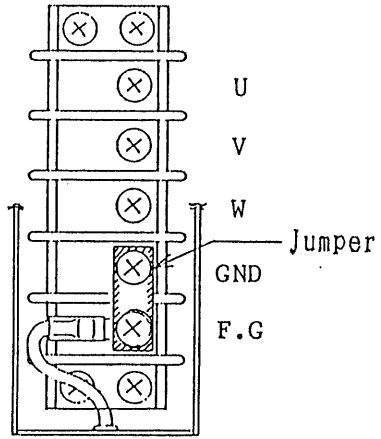

Figure 2-4A Disconnect F.G and GND

2.1.6 Rear Terminal Jumpers

- o Confirm that the jumpers of the rear terminal block are connected as shown in Figure 2-5 (when the power supply is operated in the regular conditions).

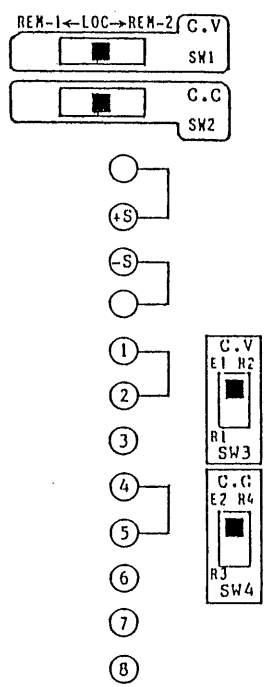

Figure 2-5

874784

4

2.1.7 Ambient Temperature

- o The ambient temperature range to meet the performance specifications of the power supply is 0 to 40 °C (32 to 104 °F). Use the power supply within this temperature range.
- o If the power supply is operated in a high ambient temperature, the over-heat protector will trip and the power switch will be cut out. When this has occurred, lower the ambient temperature and cool off the power supply and then turn on the power switch again.

NOTE: In general the lives of such electrical components as semi-conductors, electrolytic capacitors and transformer insulators are inversely and exponentially proportional to ambient temperature. It is essential to keep low the ambient temperature of the power supply from the viewpoints of its operation reliability and longevity.

- o Do not use the power supply at any ambient temperatures lower than -10°C (14 °F). Note that the performance of the power supply may become unstable at such temperatures.

2.1.8 Load Cables

- o For connections to the load, use sufficiently large cables as shown in Table 2-1. Note that, if small cables are used, the voltage at the load end may become unstable due to voltage drop in the cables and they may generate heat and become hot in extreme cases.

Table 2-1

Ta = 30° F (86° F)

Nominal Section Area	Current Limit Recommended by Kikusui	Current Limit Recommended by Electrical Installation Standard (Ordinance Article 29)
14 mm ²	50 A	88 A
22 mm ²	80 A	115 A
38 mm ²	100 A	162 A
80 mm ²	200 A	257 A
150 mm ²	300 A	395 A

874785

5

2.1.9 Particular Types of Loads

Note that the output may become unstable when the loads are particular types as follows:

(a) Pulse Current Loads

When the load current has peaks as shown in Figure 2-6 or it is of a pulse wave as shown in Figure 2-7, the peak current exceeds the preset current and the power supply is driven instantaneously to the constant-current mode for the corresponding short periods and, even though the meter reading may not be larger than the preset current limit, the output voltage may drop. This state may be indicated by the constant-current indicator lamp which may illuminate dimly.

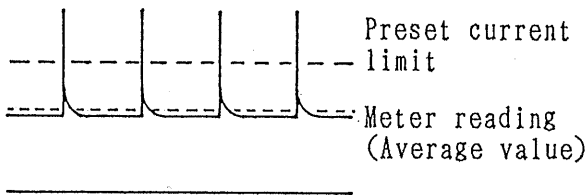

Figure 2-6 Load Current with Peaks

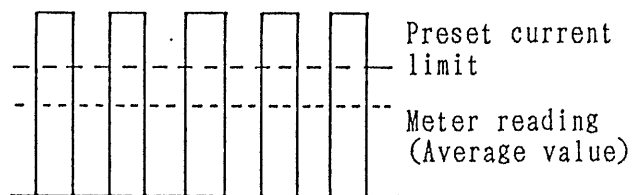

Figure 2-7 Equivalent Circuit of Pulse Waveform

In the above case, the setting of the output current should be raised or larger current capacity should be provided.

(b) Regenerative Load

Since the power supply is unable to absorb power returned from a regenerative load (such as an inverter, converter, or transformer), the output voltage may rise and become unstable.

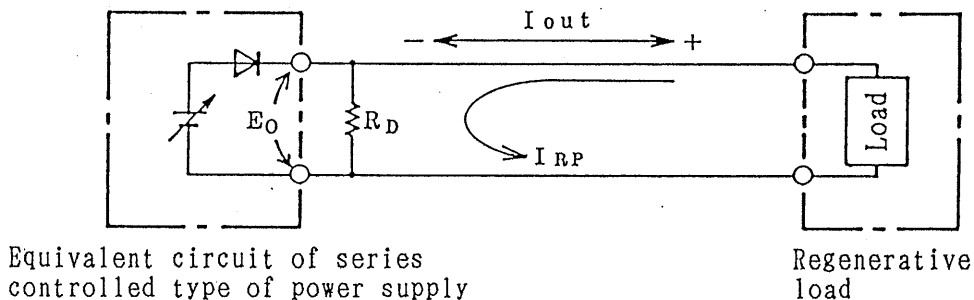

Figure 2-8

Equivalent circuit of series controlled type of power supply

Regenerative load

874786

6

In the above case, connect a resistor (R_D) to bypass the reverse current as shown in Figure 2-8. See Figure 2-9 for the reverse current and output current waveform. The resistance of R_D can be calculated as follows:

$$R_D [\Omega] \cong \frac{E_o [V]}{I_{RP} [A]}$$

where, R_D : Dummy load to bypass reverse current

E_o : Output voltage

I_{RP} : Maximum reverse current

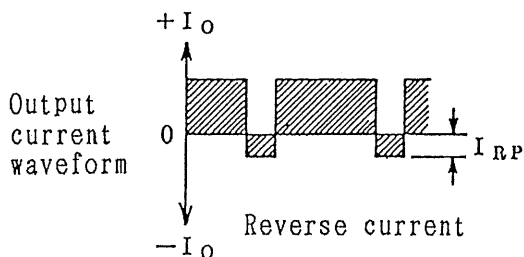

2.1.10 Guard Caps

The guard caps which are supplied accompanying the power supply may be used to make the potentiometer knobs into a fixed or a semi-fixed type in order to provide guard against unauthorized or inadvertent handling.

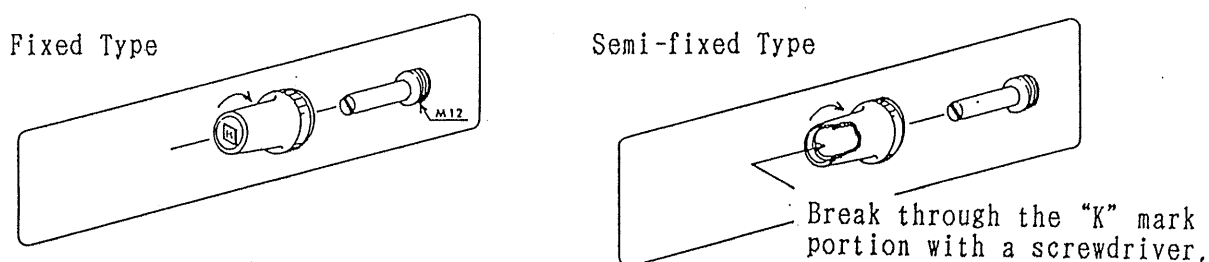

Figure 2-10

NOTE: When the power supply is operated in the remote-control mode with a voltage signal, the potentiometers on the front panel of the power supply are used as full-scale adjustment resistors. In this case, be sure to install the guard caps.

874787

7

2.2 AC Line Voltage Change

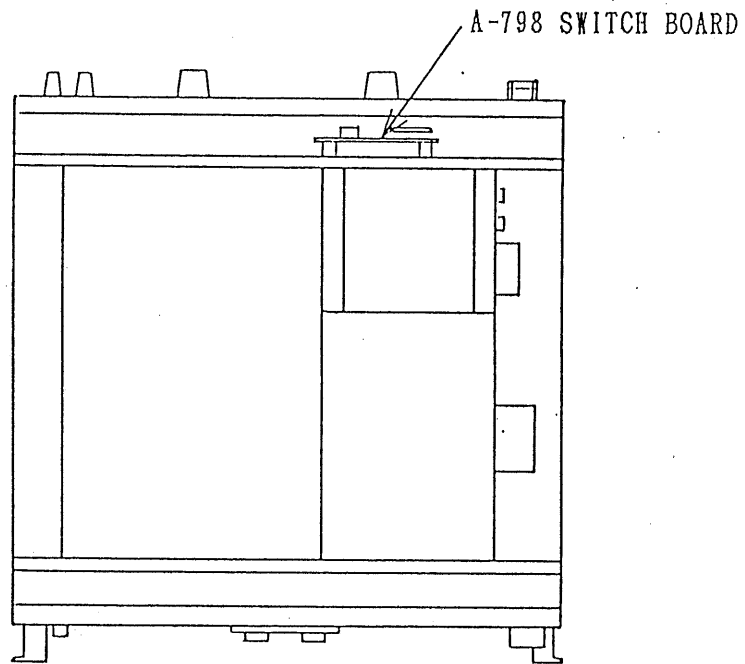

Figure 2-11

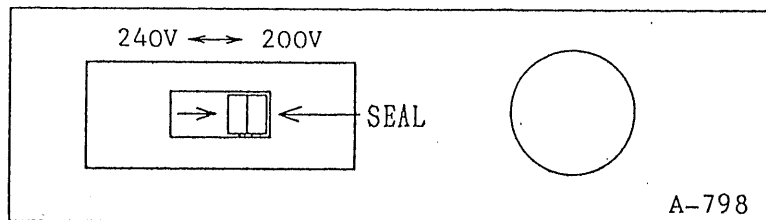

Figure 2-12 200V AC Line Input

Normally the AC line voltage of the power supply is set for 200 VAC and the AC line voltage selector switches on the A-798 board (see Figure 2-11) are sealed in the positions as shown in Figure 2-12.

874788

8

2.2.1 Change to 240 V AC Line Voltage

To change the power supply into the 240 V AC line voltage setting, proceed as follows:

- (1) Set the switches of the A-798 board as shown in Figure 2-13.
- (2) Seal the switches of the A-798 board with the "AC 240V" seals.
- (3) Post the "AC 240V" seal on the printed "AC 200V" mark at the rear input terminal block.
- (4) Change the name plate of input voltage.
(See Figures 2-13A and 2-18 ㉞.)

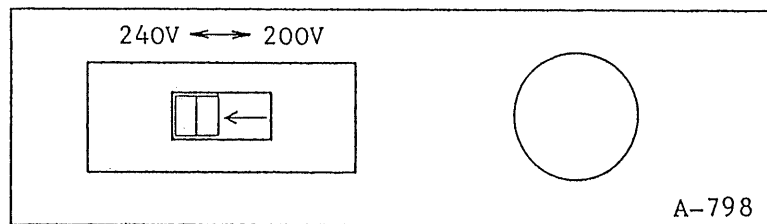

Figure 2-13 For 240V AC line

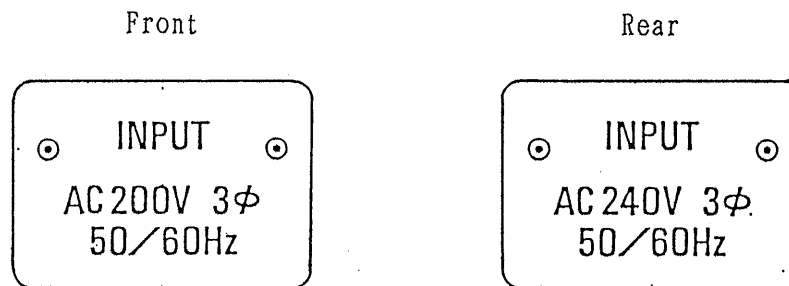

Figure 2-13A Name Plate of Input Voltage

Note : The power supply can be modified for operation on a $220V \pm 10\%$ AC line.
For this optional modification, please order your Kikusui agent.

2.3 Panel Description

① POWER Switch

- o Main input power switch of power supply.
- o The POWER switch is automatically cut out when a protector (output overvoltage protector, input overvoltage protector, input over-current protector, overheat protector, etc.) has tripped.
- o Allow a period of 5 seconds or more before turning on the POWER switch which has been cut out as above. Be sure to remedy the cause of the protector trip before turning on the POWER switch.
- o Allow a period of 1 second or more before turning on the POWER switch after turning it off manually.

NOTE: Note that the rush current suppression circuit may not operate if the POWER switch is turned on again without allowing a period of 1 second or more.

② Ammeter

- o Digital ammeter with green LED. 3-1/2 digits.

③ Current Setting Potentiometer

- o To set the constant-current output value. Effective only when in the local mode.
- o 10-turn helical potentiometer.
- o The potentiometer knob can be modified into a fixed or semi-fixed type by using the guard cap which accompanies the power supply.

④ REM-1 (Remote Current Control Mode 1 Indicator)

- o Indicates that the power supply is in the remote current control mode as selected by the rear terminal block.

874790

10

- ⑤ REM-2 (Remote Current Control Mode 2 Indicator)
 - o Indicates that the power supply is in the remote current control mode as selected by the optional internal board (option PAK-E2).
- ⑥ Voltmeter
 - o Digital voltmeter with green LED, 3-1/2 digits
- ⑦ Voltage Setting Potentiometer
 - o To set the constant-voltage output value. Effective only when in the local mode.
 - o 10-turn helical potentiometer.
 - o The potentiometer knob can be modified into a fixed or semi-fixed type by using the gurd cap which accompanies the power supply.
- ⑧ REM-1 (Remote Voltage Control Mode 1 Indicator)
 - o Indicates that the power supply is in the remote voltage control mode as selected by the rear terminal block.
- ⑨ REM-2 (Remote Voltage Control Mode 2 Indicator)
 - o Indicates that the power supply is in the remote voltage control mode as selected by the optical internal board (option PAK-E2).
- ⑩ C.C (Constant Current) Mode Indicator
 - o Indicates that the power supply is in the constant-current mode. Red LED.
- ⑪ C.V (Constant Voltage) Mode Indicator
 - o Indicates that the power supply in in the constant-voltage mode. Green LED.

874791

⑫ OUTPUT Switch

- o Turns on or off the output.
- o Automatic reset type of switch, which has been reset to the off state whenever turning on the input POWER switch, thereby enhancing the operation safety.
- o An electronic switch which does not generate chattering or other noise.
- o This switch can be disabled by SW5 (3rd element of DIP SW) on the rear panel. (Refer to Section 4.1 and 4.2)

PRECAUTIONS: The OUTPUT switch does not mechanically open the output circuit even when the switch is set to the off state. Note that the output circuit remains electrically connected even when in the off state.

⑬ Output Indicator

- o Illuminates when the OUTPUT switch is in the on state. Yellow LED.

⑭ LIMIT (Current/Voltage Limit Switch)

- o As you press this switch, the voltmeter displays the preset constant-voltage value and the ammeter the preset constant-current value.
- o By means of this switch, presetting of the constant-voltage value or constant-current value can be made with the OUTPUT switch set in the off state. Even when the OUTPUT switch is set in the on state, the preset values can be confirmed without disturbing the output.

NOTE: If you press this switch and ⑮ OVP Preset Switch at the same time, the latter has a priority and the voltmeter displays the preset OVP voltage.

874792

⑮ OVP (Overvoltage Protector Trip Voltage Preset Switch)

- o As you press the OVP switch, the voltmeter displays the preset trip voltage of the overvoltage protector. Thus the switch allows you to check the preset trip voltage without disturbing the output even when it is being delivered.

When the OVP circuit has tripped, the oscillation stops and the power switch is cut out.

NOTE: If you press the OVP switch and ⑭ LIMIT Switch at the same time, the OVP switch has a priority and the voltmeter displays the preset trip voltage.

⑯ OVP Setting Potentiometer

- o Keeping the OVP switch pressed, you can preset the trip voltage by turning this potentiometer with a screwdriver. The preset voltage is displayed on the voltmeter.

(Refer to Section 1.1 Specification. Overvoltage Protector; Setting range)

⑰ CROWBAR Mode Indicator (Option PAK-P)

- o This lamp indicates that the power supply is in the crowbar mode. (Refer to Section 4.5.)

⑱ ALARM Lamp

- o This lamp is turned on when the overvoltage protector has tripped. (Normally, however, the lamp does not illuminate as the POWER switch is cut out.) When an optional board (PAK-E2) is provided, turning off of the POWER switch is disabled by means of SW5 (4th element of DIP SW) on the rear panel. In this case the lamp illuminates to indicate the overvoltage trip status.

⑱ Service Panel

- o The service panel has potentiometers for the following calibrations and adjustments:
 - A. : Ammeter full scale calibration
 - V. : Voltmeter full scale calibration
 - A. : Output current offset adjustment when in REM-1
 - V. : Output voltage offset adjustment when in REM-1
 - AL. : Ammeter full scale calibration when in limit mode
 - VL. : Voltmeter full scale calibration when in limit mode
 - AL. : Ammeter offset adjustment when in limit mode
 - VL. : Voltmeter offset adjustment when in limit mode

⑳ VOLTAGE CHECK Terminals

- o An output voltage can be checked through these terminals. (between ⊕ and ⊖)

㉑ Air Intake Louver

- o To intake the cooling air. Clean the filter periodically.

㉒ GP-IB Control Status Indicators

GP-IB board is optional (option PAK-E2). The status indications are as follows:

- o GP-IB: Indicates that the system is in the GP-IB control mode.
- o LISTEN: Indicates that the GP-IB board is designated as a listener on the GP-IB bus.
- o TALK: Indicates that the GP-IB board is designated as the talker on the GP-IB bus.

874794

- o SRQ: Indicates that a service request is being sent on the GP-IB bus.
- o OVP REM: Indicates that OVP is remote-controlled with the GP-IB board.

②③ Terminal Block

- o This terminal block has terminals for remote sensing, terminals for remote control with voltage or resistance signal, terminals for on/off control of output, and terminals for master-slave parallel operation. (Refer to Section 4.)

②④ C.V REMOTE/LOCAL Selector Switch (SW1)

- o See the description of the next item.

②⑤ C.C REMOTE/LOCAL Selector Switch (SW2)

- o The above C.V and this C.C selector switches independently select the following statuses:

- REM-1 (Remote 1): Remote control via terminal block
②③
- REM-2 (Remote 2): Remote control by means of GP-IB board (Option PAK-E2)
- LOCAL (Local): Manual control at front panel

②⑥ C.V Remote Control Selector Switch (SW3)

- o See the description of the next item.

②⑦ C.C Remote Control Selector Switch (SW4)

- o The above C.V and this C.C switches select the remote control mode for C.V or C.C. (Refer to Section 4.)

②⑧ Blank Panel

- o A panel for space for GP-IB board (option PAK-E2)

874795

A

②⑨ Serial Number

- o An identification number of the power supply.

③⑩ Air Vent Openings

- o Hot air comes out of these openings. Provide a clearance of 30 cm (1 ft) or more from these openings.

③⑪ OUTPUT Terminals

- o These terminals (M8) delivers the output of the power supply.

③⑫ GND Terminal

- o To ground the output, either for positive ground or negative ground.

③⑬ DIN Terminal

- o Connects the contact signals for the C.V mode, C.C mode, and OVP trip status.

③⑭ INPUT Terminals

- o Terminals for AC input power of the power supply. (M5)

③⑮ SW5 (DIP SW)

- o Switch to select the various functions as described in Section 4.

③⑯ Indication Plate of Input Voltage

- o (Refer to Section 2.2.)

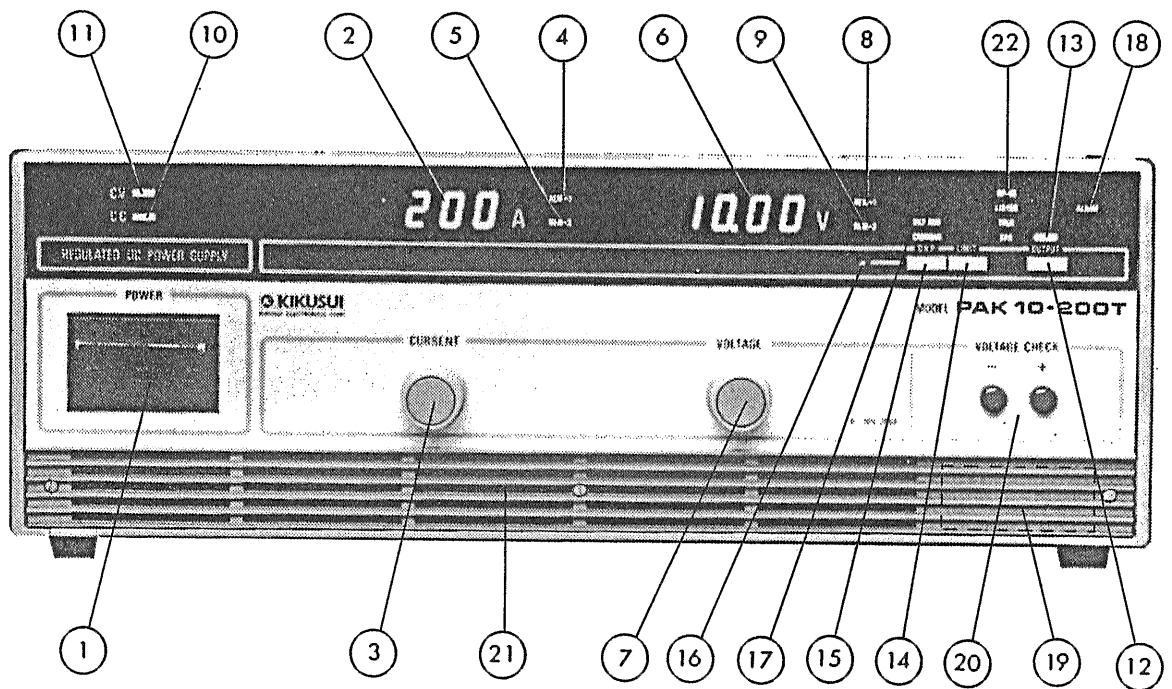

Figure 2-17

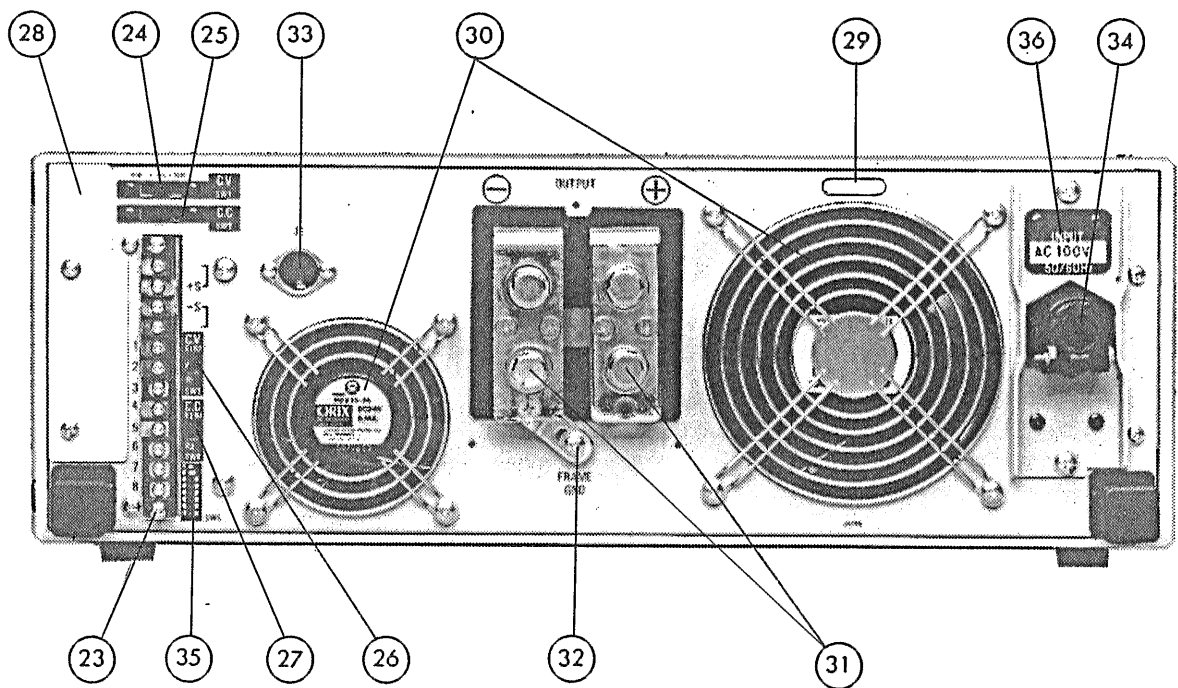

Figure 2-18

874797

///

2.4 Operation Method

2.4.1 Connection Method of Input Power Cord

1. Remove the input power cord bracket.

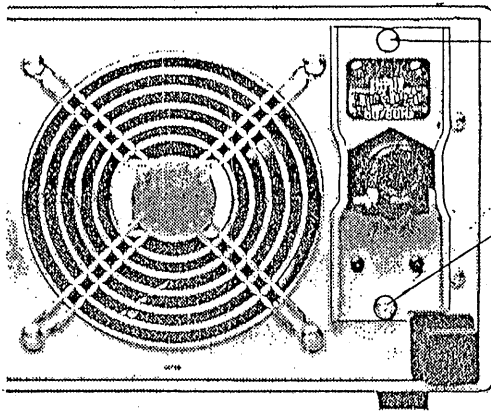

To remove the input power cord bracket, remove these two screws.

Figure 2-19

2. Cut away the unnecessary one of the clamps of the cord stopper, to suit the diameter of the input power cord which is supplied accompanying the power supply. (The clamp can be easily cut away by using a knife or other tool. See Figure 2-20.)
3. Pass the input power cord through the bracket from its back side and tighten slightly the cord-clamping screw. (See Figure 2-21.)

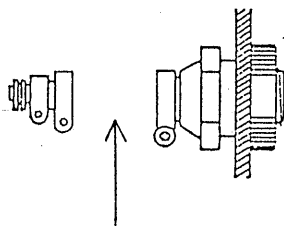

Cut away the unnecessary one of the cable clamps.

Figure 2-20

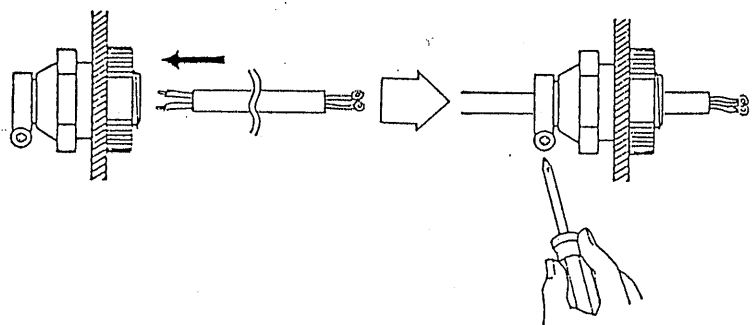

Figure 2-21

4. Connect the four core wires (with crimped terminals) of the cord to the input terminals (M4 screw terminals, for U, V, W phases and GND) of the terminal block (see Figure 2-27). Fix the bracket to the mainframe with the two screws. Adjust the cord to a slack state and, in this state, fully tighten the cord-clamping screw. (The phases are free. Any phase lines of the power cord can be connected to any phase terminals (U, V, W) of the terminal block.)

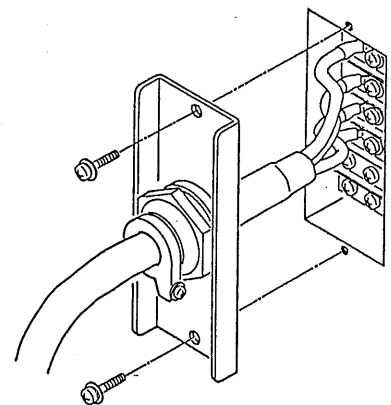
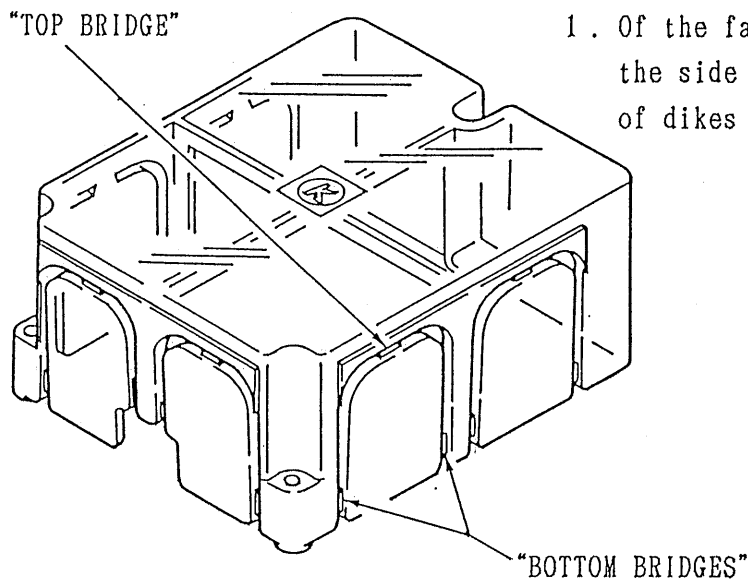

Figure 2-27

2.4.2 Preparing the Output Terminal Cover

The output terminal cover has removable facets to provide a hole for the output cables. Remove one of the facets of the direction in which the output cables are to be run. To remove the facet, break its three bridges (two at the sides and one at the top).



1. Of the facet to be removed, break the side bridges, using a pair of dikes or other tool.

Figure 2-22

2. Break the top bridge by bending the facet upward as shown with the arrowhead in Figure 2-23.

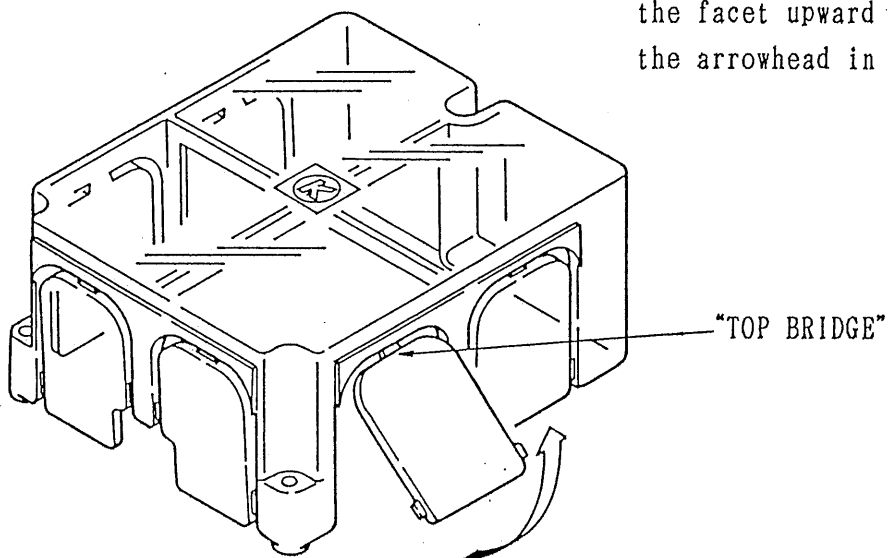

Figure 2-23

2.4.3 Constant-voltage Operation

1. Confirm the mode switches and terminal jumpers of the rear panel to standard states as shown in Figure 2-25.
2. Turn off the OUTPUT switch.
3. Turn on the POWER switch.
4. Keeping depressed the current/voltage LIMIT switch, set the output voltage at the required value with the voltage setting knob. Keeping the switch depressed yet, set the output current limit value with the current setting knob.

(By the above procedure, the output voltage and current ranges of the power supply are defined. For any load, the power supply does not deliver a voltage or a current exceeding the ranges. When the load resistance is large, the output voltage is at the set value and no large output current flows. When the load resistance is gradually reduced, the output current gradually increases up to the value preset by the current setting knob, and when the resistance is reduced further, the output current remains at the preset limit value and the output voltage decreases. The output current does not exceed the preset limit value even when the load resistance is reduced to zero or the output of the power supply is shorted. Thus, the power supply protects the load by automatically transferring itself from the constant-voltage mode to the constant-current mode of operation.)

5. Connect the load and turn on the OUTPUT switch. The C.V lamp will illuminate, indicating that the power supply is operating in the constant-voltage mode.

NOTES: (1) When the impedance of the load is unpredictable or when the load is of a nature that its resistance sharply changes as a function of the voltage applied to it, set at first the output voltage at zero volts before turning on the OUTPUT switch, and then gradually increase the output voltage.

- (2) The output voltage of the power supply does not overshoot even when the POWER switch or the OUTPUT switch is turned on or off or when any other regular operation is done.
- (3) In general the OVP (overvoltage protector) should be set at a voltage of approximately 110% of the output voltage. The OVP trip voltage can be preset with the OVP setting potentiometer while keeping depressed the OVP preset switch so that you can read the trip voltage on the voltmeter. (For details, see Section 3.3.)
- (4) When the wiring from the power supply to the load is long, the constant-voltage characteristics at the load terminals may be degraded due to resistance and inductance of the wiring. To cancel out the inductance, connect an electrolytic capacitor of 1,000 to 10,000 microfarads of good high-frequency characteristics at the shortest distance across the load terminals. To cancel out the voltage drop caused by the wiring resistance, the remote sensing provision may be employed (see Section 4.6).

2.4.4 Constant-current Operation

1. Confirm the mode switches and terminal jumpers of the rear panel to standard states as shown in Figure 2-25.
2. Turn off the OUTPUT switch.
3. Turn on the POWER switch.
4. Keeping depressed the current/voltage LIMIT switch, set the output current at the required value with the current setting knob. Keeping the switch depressed yet, set with the voltage setting knob the maximum voltage allowed to be applied to the load.
5. Connect the load and turn on the OUTPUT switch. The C.C lamp (red) will illuminate, indicating that the power supply is operating in the constant-current mode.

874801

The power supply is of an automatic constant-voltage/ constant-current transfer type. As the load resistance increases, the output voltage increases at a rate of $[E_o(\text{output voltage}) = R_L (\text{load resistance}) \times I_o (\text{output current})]$ up to the voltage preset with the voltage setting knob. When the load resistance is increased further, the power supply automatically transfers itself into the constant-voltage mode in order that no voltages higher than the preset voltage is applied to the load.

- NOTES: (1) When the load is of a nature that its impedance largely changes due to own heat generation or of a similar nature, set the constant-voltage range with sufficient allowance within the allowable voltage range of the load.
- (2) Since the power supply has a capacitor connected between the output terminals, note that, if the load is of a nature that it causes the output voltage to change rapidly, the charge/discharge current of the capacitor may be superimposed on the load current.

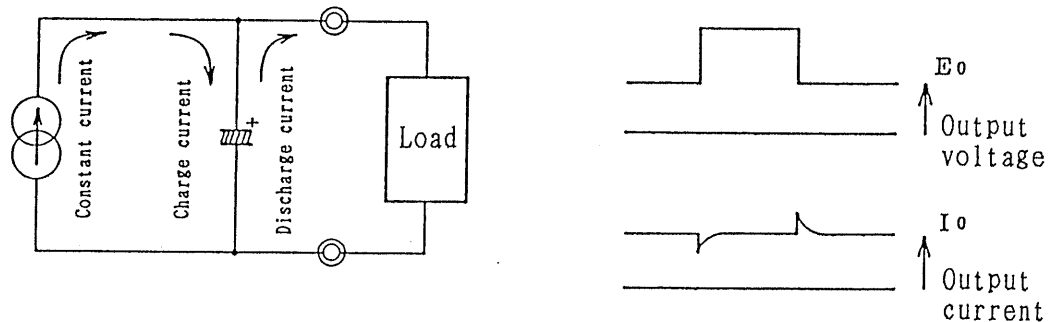

Figure 2-24

- (3) To on/off-control the output when in the constant-current mode, control it by means of the rear terminals as described in Section 4.2. Note that, if the output current is on/off-controlled with the switch, a current larger than the preset value may flow due to the above-mentioned capacitor.

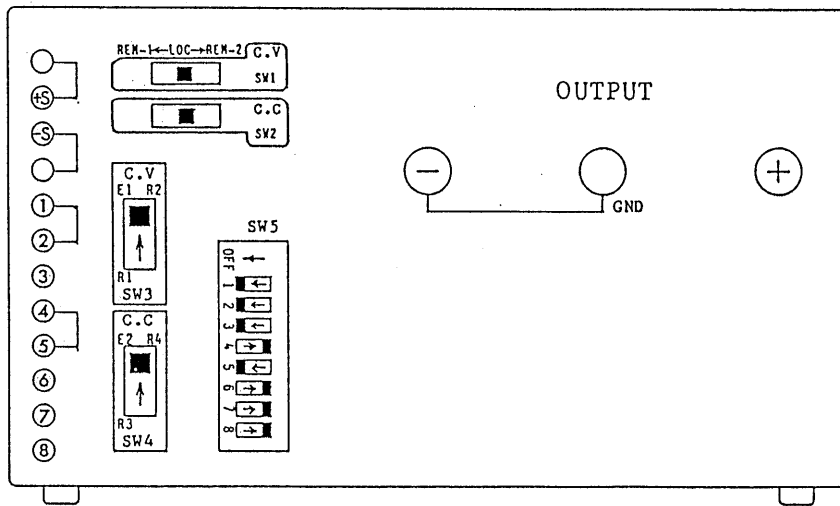

Figure 2-25. Typical Setting of Model Select Switches and Output Terminal Jumpers

874803

2.5 Contact Signals

The contact signals representing the constant-voltage mode, constant-current mode, and OVP trip status are delivered to the DIN terminal (33 in Figure 2-18). See Figure 2-26.

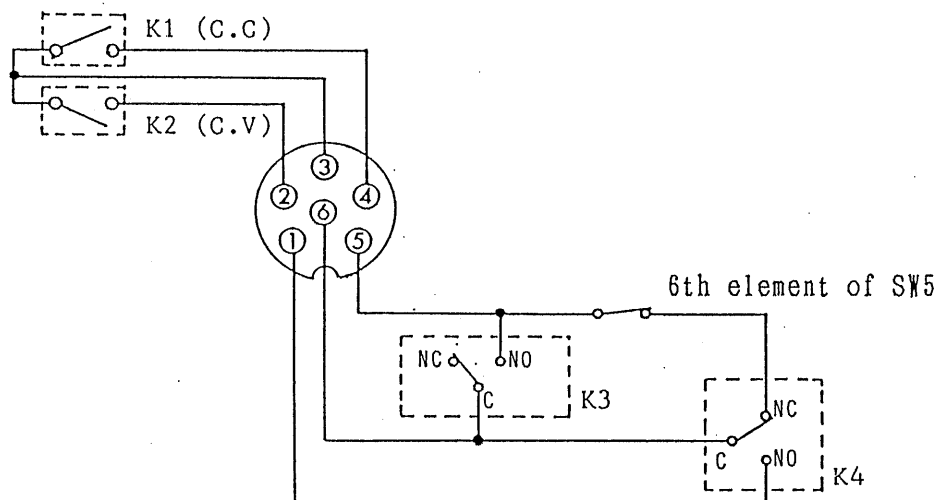

Figure 2-26

- (1) Contact Signals to Represent Constant-voltage Mode and Constant-current Mode

These signals are shown in Table 2-2.

Table 2-2

	② - ③	③ - ④
C.V	CLOSE	OPEN
C.C	OPEN	CLOSE
Power off	OPEN	OPEN
Output off		

(2) Protective Circuit Operation Indicating Contact Signals

The contact signals which represent the operating statuses of the protective circuits are as shown in Table 2-3.

Table 2-3

Operating Status	Type of Relay		Contact Signal		6th element of SW6
	K3	K4	①-⑤	⑤-⑥	
When in normal operation	NC	NO	CLOSED	OPEN	ON
<ul style="list-style-type: none"> o When POWER switch is turned off. o When overheat protector has tripped. o When input overvoltage protector has tripped. o When input overcurrent protector has tripped. o When missing-phase protector has tripped. o When OVP has tripped. <p>Mode to turn off POWER switch: 4th element of SW5 is ON. (See Section 4.4.)</p>	NC	NC	OPEN	CLOSED	
<ul style="list-style-type: none"> o When OVP has tripped. <p>Mode not to turn off POWER switch: 4th element of SW5 is OFF. (See Section 4.4.)</p>	NO	NO	CLOSED	CLOSED	
<ul style="list-style-type: none"> o When OVP has tripped. <p>Mode to turn off POWER switch: 4th element of SW5 is ON. (See Section 4.4.)</p>	NO ↓ NC	NC	OPEN	CLOSED ↓ OPEN	OFF

874805

1. The 6th element of SW5 (DIP SW) is set in the ON state on the rear panel.
2. If the 6th element of SW5 is set in the OFF state with the power supply set in the mode (4th of SW5, ON. Refer to Section 4.4.) that the POWER switch is turned off when the overvoltage protector has tripped, the contact which connects pins 5 and 6 is made for a very short period as the overvoltage protector trips, and then the contact is broken. By means of this contact signal, two or more units of power supplies which are incorporated with high speed OVP (option PAK-P) can be operated in parallel. (See Section 4.10.2.)

Contact Ratings

Maximum Operable Voltage :	24 V DC
Maximum Operable Current :	0.5 A
Maximum Allowable ON/OFF Current :	0.4 A
Maximum Contact Wattage :	10 W (DC)

3. PROTECTIVE CIRCUITS

3.1 Background

Keeping pace with the rapid advancement of electronics in these years, power supplies also have greatly advanced. They have become to render much higher accuracies, power factors, efficiencies, reliabilities, and much faster responses, and yet they are more compact, light, and economical. Today a wide variety of power supplies claiming these features are available on the market.

When choosing a power supply, attention should be paid not only to the point of satisfying the required performance but also to some points which are different for those which are paid when choosing an electronic equipment which handles signals. The differences come from the fact that the power supply plays a cardinal role of providing the "source power" for the entire electric or electronic system. Failure of the power supply can result in shut down of the entire system, in damage to the load equipment, and even fire hazards in an extreme case. Therefore, reliability not to fail is vitally important for the power supply. For protection in case of failure, the power supply should be incorporated with the various protective features. The PAK Series is incorporated with the various protective features as briefly described in this section.

3.2 Protective Circuits

(1) Overvoltage Protector (OVP)

- o When the output voltage has exceeded the preset voltage, the OVP turns off the POWER switch and stops oscillation of the switching regulator.
- o The response pulse width is 200 μ sec.
- o Allow a period of approximately 5 seconds or more before turning on the POWER switch after the OVP has tripped. Be sure to eliminate the cause of the trip before turning on the POWER switch.
- o When the load is very weak against overvoltage (such as a semiconductor device), use of the high speed overvoltage protector described in the next item (2) is recommended.

- o Such mode of operation also can be selected for GP-IB control that oscillation of the switching regulator is stopped but the POWER switch is not turned off even when the OVP has tripped. (See Section 4.4.)

(2) High Speed Overvoltage Protector (Crowbar) ... (Option PAK-P)

- o When the output voltage has exceeded the preset voltage for a period of 200 μ sec or more, the thyristor connected in the output circuit conducts to suppress the output voltage and at the same time the POWER switch is turned off and oscillation of the switching regulator is stopped.

- o Since the output terminals are shorted by the thyristor, if the load is a battery or a large capacitor, a check diode must be connected in series to the load. (See Section 4.12.)

Note: When in the crowbar mode (option PAK-P), the presettable voltage is 3 volts or more.

(3) Input Overvoltage Protector

- o When the voltage of the filter capacitor of the power supply has exceeded the preset voltage, the POWER switch is turned off and oscillation of the switching regulator is stopped.

(4) Overcurrent Protector

- o The output current does not exceed 110% of the rated output current even when erroneous remote control operation is done.
(See Section 3.2 (1).)

(5) Overheat Protector

- o When the temperature of the semiconductor heat sink has become higher than approximately 85° C(185° F) due to ambient temperature rise or fan motor failure, the POWER switch is turned off and oscillation of the switching regulator is stopped.

(6) Thermal Fuse

- o When the temperature of the sub-power-transformer has become higher

874808

than approximately 135° C(275° F), the fuse blows out to cut out the input circuit.

(7) Rush Current Suppressor

- o To suppress the rush current when the POWER switch is turned on.

(8) Input Fuse

- o To limit the input current.

3.3 Operation Method of OVP (Overvoltage Protector)

- o To set the OVP trip voltage, proceed as follows: Press the OVP preset button, and the voltmeter will indicate the OVP preset voltage. Adjust the voltage with a screwdriver. (After setting the trip voltage, increase the output voltage to test that the OVP trips at the preset voltage.)
- o The OVP trip voltage can be checked by pressing the OVP preset button without affecting the power supply operation including the protective functions.
- o As the OVP detects an overvoltage, it turns off the POWER switch and stops oscillation of the switching regulator. However, it does not actively reduce the voltage which appears at the output terminal. Therefore, for a load which is weak against overvoltage and unable to tolerate even small overvoltages of a level of several volts and 100 msec, use of the high speed OVP Crowbar (optionPAK-P) which instantaneously reduces the voltage which appears at the output terminal is recommended.
- o By means of SW5 (DIP SW), such mode of operation also is possible that, when the OVP has tripped, the POWER switch is not turned off although oscillation of the switching regulator is stopped. This mode is necessary for keeping alive the supply power for the GP-IB card which may be incorporated in the power supply. To reset the power supply when not in the GP-IB mode, turn off the POWER switch once and allow a period of 5 seconds or more before turning on the POWER switch again. (When in the GP-IB mode, the power supply can be reset also with a reset signal.)

4. APPLICATIONS

The PAK Series has a DIP switch (SW5) on the rear panel. The various modes of operation are selectable with SW5 as described in this section.

(Set the switches and terminals not indicated in Figure 4-1 as required by respective control modes.) Figure 4-2 shows SW5.

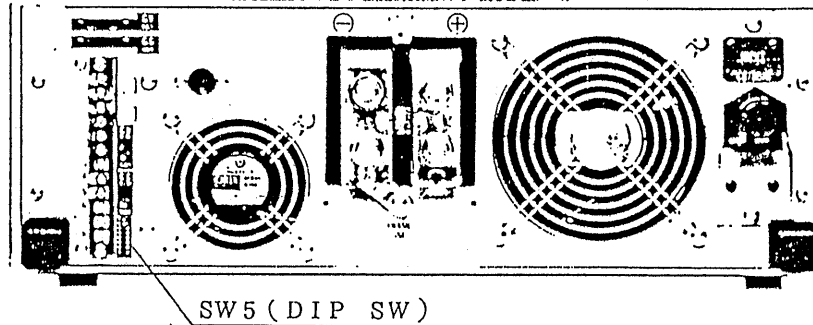

Figure 4-1

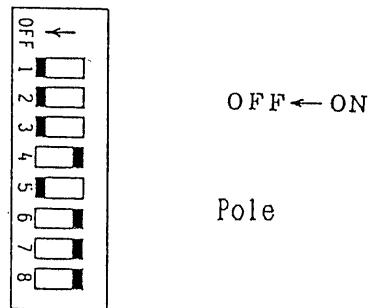

Figure 4-2 SW5 (DIP SW)

4.1 To Disable the OUTPUT Switch

With the FOD (front output switch disable) function setting as follows, the output can be delivered irrespective of setting of the OUTPUT switch.

- (1) Turn off the POWER switch.
- (2) Set the 3rd element of SW5 to the ON state.

Notes: 1. If the 3rd element is set in this state, the output voltage starts rising when the POWER switch is turned on and the soft start operation is over. Therefore, be sure to set the voltage setting knob to the fully counterclockwise position.

2. The relationship between the 3rd element of SW5 and the FOD switch of the GP-IB board (option PAK-E2) is with priority for ON. Therefore, when either one or both of them are ON, the OUTPUT switch of the front panel is disabled.

4.2 ON/OFF Control of Output

The output can be ON/OFF-controlled with an external contact signal. For this operation, proceed as follows:

- (1) Turn off the POWER switch.
- (2) Set the 3rd element of SW5 to the ON state.
- (3) Connect a remote-control contact signal (switch Sa) between terminals ⑤ and ⑦ of the rear terminal block.
- (4) Set the 1st element of SW5 depending on the required mode as shown in Table 4-1.

Table 4-1

1st Element of SW5	ON		OFF	
	OPEN	CLOSE	OPEN	CLOSE
Contact Sa	OFF	ON	ON	OFF
Output	ON	OFF	OFF	ON

- NOTES:
1. When environmental noise is large or the distance from the power supply to the control signal source is long, install a small DC relay near the power supply and extend the wiring of the relay coil to the control signal source.
 2. For wiring to the contact (Sa), use a shielded cable and connect the shielding wire of the cable to the ⑤ output terminal of the power supply.

4.3 Remote Control of POWER Switch

The POWER switch can be remote-controlled with an external contact signal. For this operation, proceed s follows:

- (1) Turn off the POWER switch.
- (2) Connect a remote-control contact signal (Sb) between terminals ⑤ and ⑥ of the rear terminal block.
- (3) Set the 2nd element of SW5 depending on the required mode as shown in Table 4-2.

Table 4-2

2nd Element of SW5	ON		OFF	
	OPEN	CLOSE	OPEN	CLOSE
POWER Switch	OFF	—	—	OFF

- NOTES:
1. When environmental noise is large or the distance from the power supply to the control signal source is long, install a small DC relay near the power supply and extend the wiring of the relay coil to the control signal source.
 2. For wiring to the contact (Sb), use a pair of stranded wires or a cable. Connect the shielding wire of the cable to the ⑤ terminal.

4.4 To Select OVP Mode

There are two OVP modes: one is to turn off the POWER switch when the OVP has tripped and the other is not to turn off the switch. When the latter mode is selected, an alarm lamp on the front panel illuminates. The latter mode is used primarily when the power supply is operated through its GP-IB board (option PAK-E2). To select an OVP mode, proceed as follows:

- (1) Turn off the POWER switch.
- (2) Set the 4th element of SW5 to the required position referring to Table 4-3.

Table 4-3

4th Element of SW5	ON	OFF
Operation of POWER switch when OVP has tripped	Turned off	Not turned off. Oscillation stops. (See Note 1.)

- NOTES:
1. When the OVP has tripped with the 4th element of SW5 set in the OFF state, the OUTPUT switch remains in the ON state although the switching regulator stops oscillating and no output is delivered. To reset the power supply, turn off the POWER switch and, after allowing a period of 5 seconds or more, turn on the POWER switch. If the GP-IB board (option PAK-E2) is incorporated, the power supply can be reset with the reset signal.
 2. The POWER switch is turned off when the overheat protector, input overvoltage protector or input overcurrent protector has tripped.

4.5 To Select Crowbar (High Speed Thyristor OVP) Mode

If your power supply is incorporated with the high speed OVP thyristor (option PAK-P), you can select either the regular OVP mode or the high speed OVP mode (thyristor crowbar mode). When you have selected the latter mode, the CROWBAR indication is made on the front panel. To select a mode, proceed as follows:

- (1) Turn off the POWER switch.
- (2) Set the 5th element of SW5 to the required mode referring to Table 4-4.

Table 4-4

5nd Element of SW5	ON	OFF
OVP	Crowbar	Regular

- Notes:
1. Be sure to refer to Sections 3.2 and 3.3 before employing the crowbar mode.
 2. When the 5th element of SW5 is set to the ON state, the CROWBAR indication on the front panel is made even when the power supply is not incorporated with the high speed OVP thyristor.

4.6 Remote Sensing

The remote sensing setup is employed to compensate for voltage drop caused by wiring from the power supply to the load and for degradation of voltage stability at the load end due to contact resistances. For this setup, proceed as follows:

- (1) Turn off the POWER switch.
- (2) Disconnect the jumper strips from between terminals \oplus and \oplus and between terminals \oplus and \ominus .
- (3) To the points where the voltage is to be sensed for stabilization, connect the \oplus and \ominus terminals employing a shielded cable and observing the correct polarity. (Employ a shielded cable in order to prevent induction noise. Connect the shielding wire of the cable to the \ominus terminal of the power supply.)
- (4) Connect an electrolytic capacitor (C1) of 1,000 to 10,000 microfarads with good high-frequency characteristics to the sensing points (the points to which the \oplus and \ominus are connected) in the shortest distance.

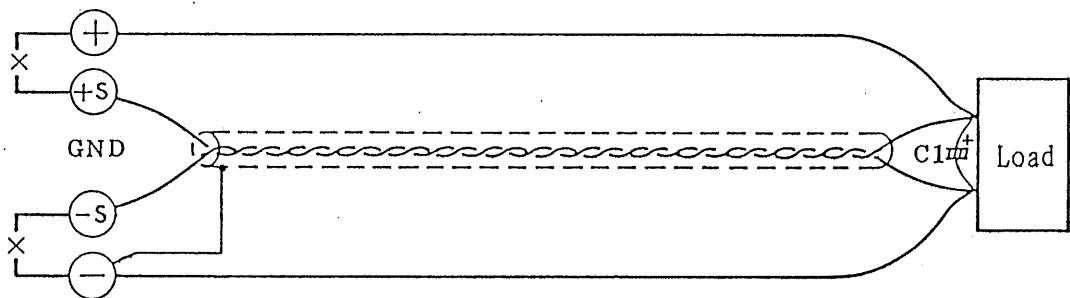

Figure 4-3

Notes: 1. When the above setup, voltage drop of up to 1.0V per one way of wiring can be compensated for. The available output voltage is reduced by the amount of voltage drops caused in the wiring. (For example, when the voltage drop per one way is 1V, the maximum available output voltage is reduced by 2V from the maximum rated output voltage (10V) and becomes as $10V - 2V = 8V$. Do not attempt to deliver an output voltage high than 8V.)

874815

2. When the wiring distance is long, the output impedance at the load end may become high due to the inductance of the wiring cable and the stability of the voltage at the load end may be degraded. Also, a substantial phase shift may be caused and oscillation may result. Be sure to connect an electrolytic capacitor (C1) at the load end.

3. When the load is of a nature that it draws an intermittent or pulsewise current, the voltage stability at the load end may be badly degraded due to the capacitor (C1) and the wiring cable inductance (L) which causes a voltage of $L \frac{di}{dt}$. To prevent this, use large wires for wiring, make the wiring distance as short as possible, and strand the wires to reduce inductance.

4.7 Remote Control of Output Voltage

The output voltage can be remote-controlled in three modes, namely, control of the output voltage with an external voltage signal, linear control of the output voltage with an external resistance signal, and fail-safe control of the output voltage with an external resistance signal. This section describes these remote control modes of operation.

4.7.1 Control of Output Voltage with External Voltage Signal

The output voltage can be remote-controlled with an external voltage of 0 to +10V with reference to the ⊕ terminal. For this setup, proceed as follows:

- (1) Turn off the POWER switch.
- (2) Disconnect the jumper from between terminals ① and ② of the rear terminal block.
- (3) Throw the SW1 switch on the rear panel to REM-1.
- (4) Throw the SW3 switch on the rear panel to E1.
- (5) Connect the remote control voltage signal (E1) to between terminals ⊕ and ①, with terminal ① for the positive polarity line.
- (6) Turn on the POWER switch. (Turn on the OUTPUT switch.)
- (7) Adjust offset(at zero volts)with the V.os control of the service panel.
- (8) Regarding the switches for which no settings are specified in Figure 4-4, set them to the standard states as shown in Figure 2-25 (See Section 2.4.) or to appropriate states for respective modes (See Sections 4.1 through 4.11.).

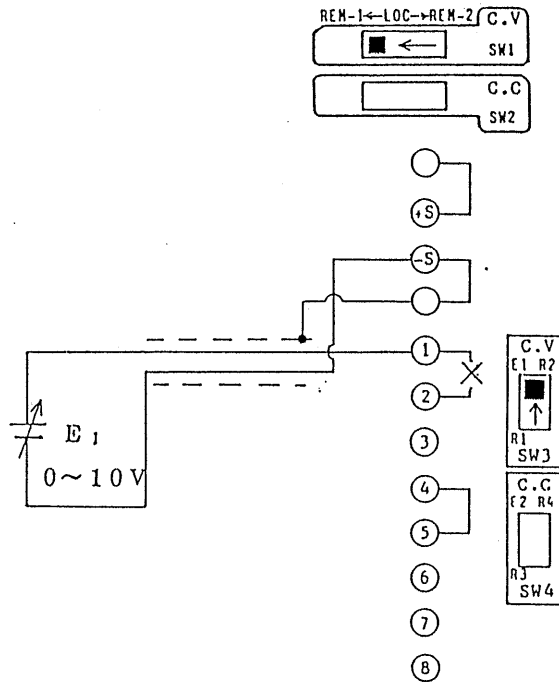

Figure 4-4

PRECAUTIONS: Wrong wiring or other erroneous setup or application of over-voltage can result in damage to the equipment. Make sure that the setup has been correctly made before turning on the POWER switch.

- Notes:
1. Never attempt to deliver an output voltage higher than the rated output voltage of the power supply.
 2. The input resistance between terminals ⑤ and ① is approximately 10 k Ω .
 3. The control voltage signal (E1) must be with less noise (less ripples) since the noise is amplified and appears at the output terminal. For signal wiring, use a shielded cable (or a pair of stranded wires) and connect the shielding wire of the cable to the ① OUTPUT terminal. Pay attention to noise especially when the wiring distance is long.
 4. Offset Adjustment: Adjust so that the output voltage becomes zero volts when the control voltage signal is zero volts.

4.7.2 Linear Control of Output Voltage with External Resistance Signal

The output voltage can be remote-controlled with an external resistance signal. For this setup, proceed as follows:

- (1) Turn off the POWER switch.
- (2) Throw the SW1 switch of the rear panel to REM-1.
- (3) Throw the SW3 switch of the rear panel to R1.
- (4) Disconnect the jumper from between terminals ① and ② of the rear terminal block.
- (5) Connect a control resistor (R1) between terminals ① and ②.
- (6) Turn on the POWER switch. (Turn on the OUTPUT switch.)
- (7) Adjust offset (at zero volts) with the V.os control of the service panel.
R1 = 0 (Ω) (See Section 4.7.1, Note 4.)
- (8) Regarding the switches for which no settings are specified in Figure 4-5, set them to the standard states as shown in Figure 2-25 (See Section 2.4.) or to appropriate states for respective modes (See Sections 4.1 through 4.11.).

PRECAUTIONS: Note that the equipment may be damaged unless the setup is made correctly. (Note that the output can run away if R1 is made open.) Before turning on the POWER switch, make sure that the setup has been correctly done.

874819

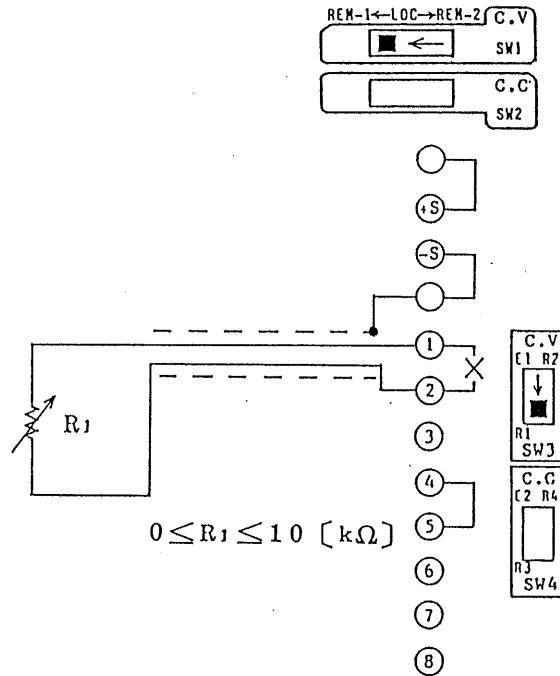

Figure 4-5

- o The relationship between the output voltage (E_o) and control resistance (R_1) is as follows:

$$E_o \text{ [V]} = \frac{R_1 \text{ [k}\Omega\text{]}}{10 \text{ [k}\Omega\text{]}} \times E_{\text{max}} \text{ [V]}$$

where, E_{max} : Maximum rated output voltage

- Notes:
1. Never attempt to deliver an output voltage higher than the rated output voltage of the power supply.
 2. The control resistor (R_1) is connected in the feedback loop of the operational amplifier. If this resistor is made open, an overvoltage will appear in the output circuit of the power supply. When controlling the output voltage employing a switch for example, use a make-before-break type of switch to prevent opening of the control resistance circuit. (When this output instability due to open-circuiting is not tolerable from the viewpoint of reliability or safety, use the method described in Section 4.7.3.)

3. The current which flows in the control resistor (R1) is constant at 1mA. For the resistor, use a quality resistor of 1/2 watt or more, with good temperature coefficient, aging and noise characteristics (such as a metallic film resistor.)
4. For wiring to the control resistor (R1), use a shielded cable and connect its shielding wire to the \ominus terminal of the power supply. When the wiring distance is long, pay attention to ripple and other induction noise.
5. Pay attention to the voltage drop caused by the wiring since it will cause an offset voltage.

4.7.3 Fail-safe Control of Output Voltage with External Resistance Signal

This fail-safe feature is such that, should the control resistance signal circuit is made open, the output voltage is reduced. With this feature, control resistors can be safely switched with a switch or a relay, without overshoots of the output voltage. A disadvantage of this setup is that the output voltage is not directly proportional to the control resistance. Especially for low voltages, large resistances are needed. For this setup, proceed as follows:

- (1) Turn off the POWER switch.
- (2) Throw the SW1 switch on the rear panel to REM-1.
- (3) Throw the SW3 switch on the rear panel to R2.
- (4) Disconnect the jumper from between terminals ① and ② of the rear terminal block.
- (5) Connect a control resistor (R2) between terminals ① and ③.
- (6) Regarding the switches for which no settings are specified in Figure 4-6, set them to the standard states as shown in Figure 2-25 (See Section 2.4.) or to appropriate states for respective modes (See Sections 4.1 through 4.11.).

- o The relationship between the output voltage (Eo) and control resistance (R2) is as follows:

$$E_o [V] = \frac{10 [k\Omega]}{(10 + R_2) [k\Omega]} \times E_{max} [V]$$

where, E_{max}: Maximum rated voltage

$$0 \leq R_2 \leq \infty$$

874822

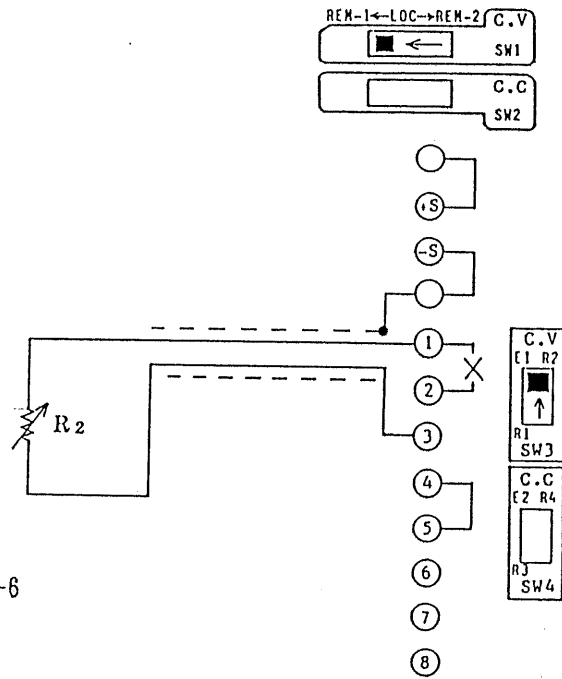

Figure 4-6

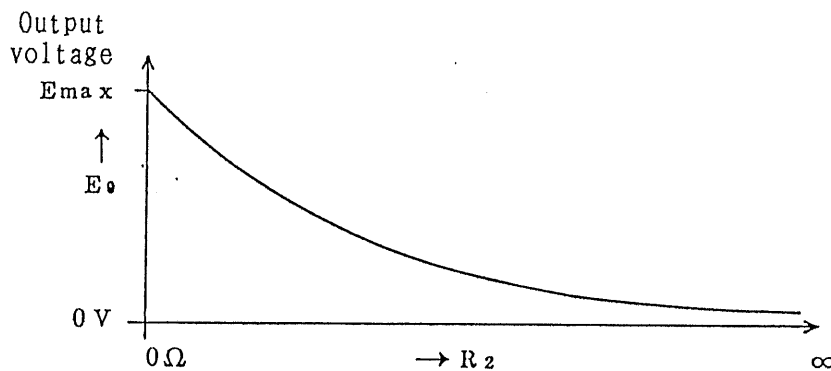

Figure 4-7

- Notes:
1. o The maximum voltage applied to the control resistor (R_2) is approximately 10V and the maximum current fed to the resistor is 1 mA.
 - o Use quality resistors with good temperaure coefficient, and good aging and noise characteristics.
 - o Note that, when the resistance of R_2 is several hundreds killo-ohms or more, the output characteristics may be degraded due to induction noise.
 2. o For wiring to R_2 , use a shielded cable and connect its shielding wire to the \ominus OUTPUT terminal of the power supply.

4.8 Remote Control of Output Current

The output current can be remote-controlled in three modes, namely, control of the output current with an external voltage signal, linear control of the output current with an external resistance signal, and fail-fuse control of the output current with an external resistance signal. This section describes these remote control modes of operation.

4.8.1 Control of Output Current with External Voltage Signal

The output current can be remote-controlled with an external voltage of 0 to 10V with reference to the \ominus OUTPUT terminal. For this setup, proceed as follows:

- (1) Turn off the POWER switch.
- (2) Throw the SW2 switch of the rear panel to REM-1.
- (3) Throw the SW4 switch of the rear panel to E2.
- (4) Disconnect the jumper from between terminals ④ and ⑤ of the rear terminal block.
- (5) Connect the remote control voltage (E2) to between terminals ⑤ and ④, with terminal ④ for the positive polarity line.
- (6) Connect an ammeter (a shunt resistor) between the OUTPUT terminal.
- (7) Turn on the POWER switch. (Turn on the OUTPUT switch.)
- (8) Adjust offset (at zero amperes) with the A.os control of the service panel.
- (9) Regarding the switches for which no settings are specified in Figure 4-8, set them to the standard states as shown in Figure 2-25 (See Section 2.4.) or to appropriate states for respective modes (See Sections 4.1 through 4.11.).

PRECAUTIONS: Wrong wiring or other erroneous setup or application of over-voltage can result in damage to the equipment. Make sure that setup has been correctly made before turning on the POWER switch.

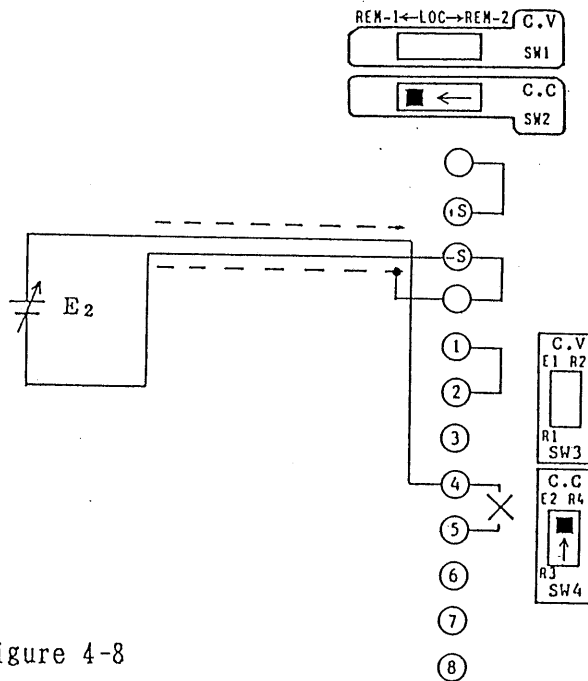

Figure 4-8

- o The relationship between the output voltage (\$I_o\$) and control voltage (\$E_2\$) is as follows:

$$I_o \text{ [A]} = \frac{E_2 \text{ [V]}}{10 \text{ [V]}} \times I_{max}$$

where, \$I_{max}\$: Maximum rated current

$$0 \leq E_2 \leq 10 \text{ [V]}$$

- Notes:
1. Never attempt to deliver an output current larger than the rated output current of the power supply.
 2. The input resistance between terminals ⊕ and ⊖ is 20 to 30 kΩ.
 3. The control voltage signal (\$E_2\$) must be with less noise (less ripples) since the noise is amplified and appears at the output terminal.
 4. For signal wiring, use a shielded cable and connect the shielding wire of the cable to the ⊖ OUTPUT terminal. Pay attention to noise especially when the wiring distance is long.
 5. Offset Adjustment: Adjust so that the output current becomes zero amperes when the control voltage signal is zero volts.

4.8.2 Linear Control of Output Current with External Resistance Signal

The output current can be remote-controlled with an external resistance signal in a linearly proportional mode. As the output current is linearly proportional to the control resistance, this setup is optimal for programmed remote control. For this setup, proceed as follows:

- (1) Turn off the POWER switch.
- (2) Throw the SW2 switch of the rear panel to REM-1.
- (3) Throw the SW4 switch of the rear panel to R3.
- (4) Disconnect the jumper from between terminals ④ and ⑤ of the rear terminal block.
- (5) Connect a control resistor (R3) to between terminals ④ and ⑤.
- (6) Connect an ammeter (a shunt resistor) between the OUTPUT terminals.
- (7) Turn on the POWER switch. (Turn on the OUTPUT switch.)
- (8) Adjust offset (at zero amperes) with the A.os control of the service panel. $R3 = 0 (\Omega)$ (See Section 4.8.1, Note 5.)
- (9) Regarding the switches for which no settings are specified in Figure 4-9, set them to the standard states as shown in Figure 2-25 (See Section 2.4.) or to appropriate states for respective modes (See Sections 4.1 through 4.11.).

PRECAUTIONS: Note that the equipment may be damaged unless the setup is made correctly. (Note that the output can run away if R3 is made open.) Before turning on the POWER switch, make sure that the setup has been correctly done.

874826

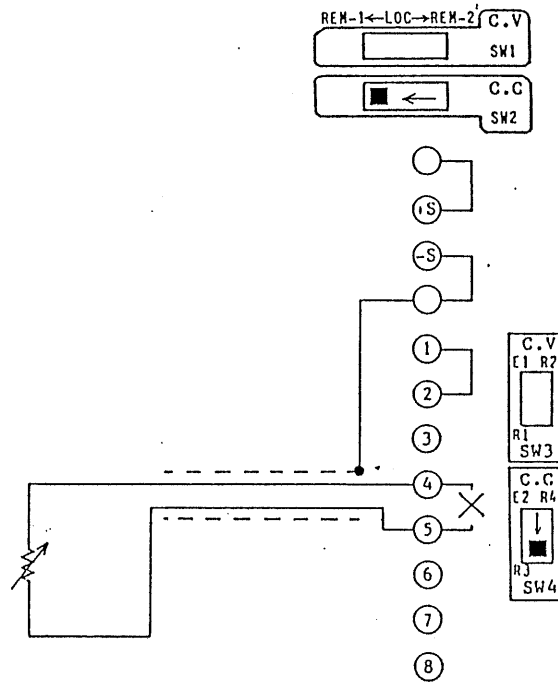

Figure 4-9

Relationship between output current (I_o) and control resistance (R_3) is as follows:

$$I_o \text{ [A]} = \frac{R_3 \text{ [k}\Omega\text{]}}{10 \text{ [k}\Omega\text{]}} \times I_{max}$$

where, I_{max} : Maximum rated current

$$0 \leq R_3 \leq 10 \text{ [k}\Omega\text{]}$$

- Notes:
1. Never attempt to deliver an output current larger than the rated current of the power supply.
 2. The control resistor (R_3) is connected in the feedback loop of the operational amplifier. If this resistor is made open, an over-current will be caused. When controlling the output current employing a switch for example, use a short-circuit type of switch to prevent opening of the control resistance circuit. (When this output instability due to open-circuiting is not tolerable from the viewpoint of reliability or safety, use the method described in Section 4.8.3.)
 3. The current fed to R_3 is 1mA constant. For R_3 , use a quality resistor of 1/4 watt or more, with good temperature coefficient, aging and noise characteristics. (such as a metallic film resistor)

874827

4. For wiring to the control resistor (R3), use a shielded cable and connect the shielding wire to the \ominus OUTPUT terminal of the power supply.

When the wiring distance is long, pay attention to ripple and other induction noise. This is especially important when environmental noise is large.

5. Note that the resistance of the wiring cable causes an offset current.

4.8.3 Fail-safe Control of Output Current with External Resistance Signal

This fail-safe feature is such that, should the control resistance signal circuit is made open, the output current is reduced. With this feature, control resistors can be safely switched with a regular switch or a relay, without overshoots of the output current. A disadvantage of this setup is that the output current is not directly proportional to the control resistance. Especially for low currents, large resistances are needed. For this setup, proceed as follows:

- (1) Turn off the POWER switch.
- (2) Throw the SW2 switch of the rear panel to REM-1.
- (3) Throw the SW4 switch of the rear panel to R4.
- (4) Disconnect the jumper from between terminals ④ and ⑤ of the rear terminal block.
- (5) Connect a control resistor R4 between terminals ③ and ④.
- (6) Regarding the switches for which no settings are specified in Figure 4-10, set them to the standard states as shown in Figure 2-25 (See Section 2.4.) or to appropriate states for respective modes (See Sections 4.1 through 4.11.).

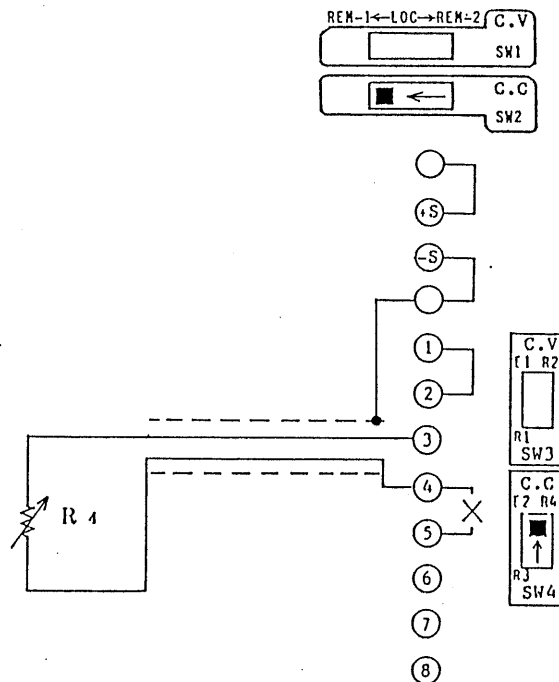

Figure 4-10

Relationship between output current I_o and control resistance R_4 is as follows:

$$I_o [A] = \frac{10 [k\Omega]}{(10 + R_4) [k\Omega]} \times I_{max} [A]$$

where, I_{max} : Maximum rated current

$$0 \leq R_4 \leq \infty$$

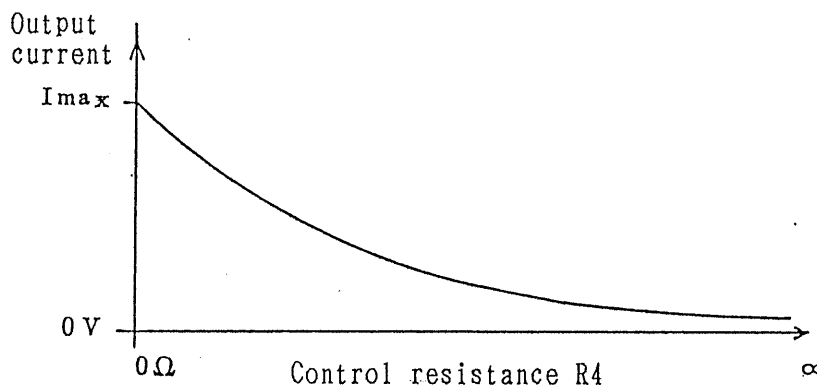

Figure 4-11

- Notes: 1. The maximum voltage and current applied or fed to R_4 is 10V and 1mA. For R_3 , use a quality resistor(s) of good temperature coefficient, aging and noise characteristics.

When the resistance of R_4 is 100k Ω or more, the output characteristics may be degraded due to induction noise.

2. For wiring to the control resistor (R_4), use a shielded cable and connect its shielding wire to the \ominus OUTPUT terminal of the power supply.

When the wiring distance is long, pay attention to ripple and other induction noise.

4.9 Series or Parallel Operation

4.9.1 Series Operation

Two or more PAK Series power supplies can be connected in series as shown in Figure 4-12 to deliver a higher output voltage.

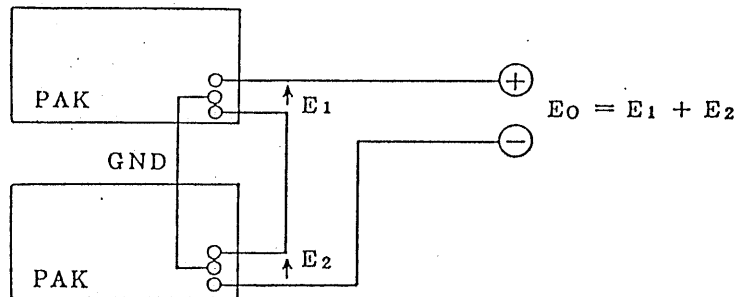

Figure 4-12

- Notes:
1. The number of power supplies which can be connected in series is limited by the allowable voltage (250V) with respect to the ground. (For example, when the output voltage of each unit of power supplies is set at 10V, up to 25 units can be connected in series as $250 \div 10 = 25$.)
 2. In order to eliminate the potential differences of the units, connect together the GND terminals of all units to a line of the potential you may require.
 3. Be sure to operate all units in the state that their POWER switches are turned on.

874831

4.9.2 Parallel Operation

Two or more PAK Series power supplies can be connected in parallel as shown in Figure 4-13 to deliver a larger output current.

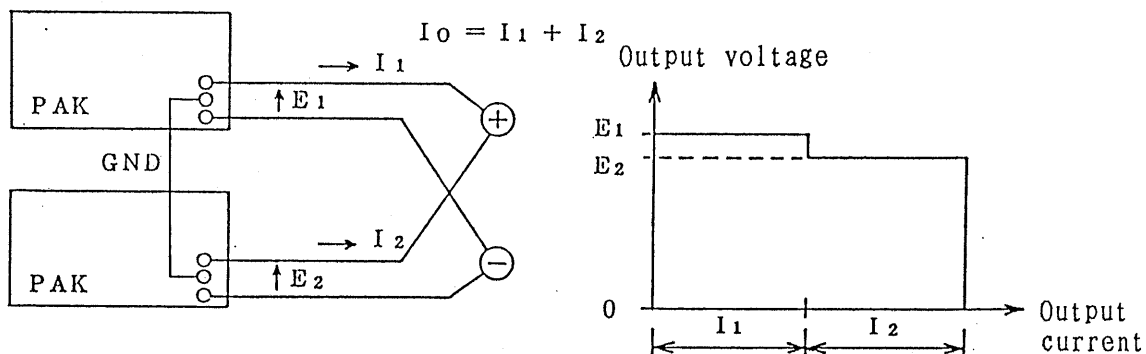

Figure 4-13

- Notes:
1. Pay attention so that no voltages higher than the rated voltage is applied to the output circuit.
 2. When operating the units in the constant-voltage mode, make uniform the output voltages of the units. At first the output current is delivered by the unit whose output voltage is the highest among those of the units connected in parallel. When the output current has increased and the first unit is transferred into the constant-current mode and its output voltage is reduced, the next unit starts delivering its output current. Thus, one of the units connected in parallel operates in the constant-voltage mode. Differences of the output voltages of the units connected in parallel are reflected onto the regulation degradation of the supply voltage for the load.

When operated in the constant-current mode, the C.C mode lamps of all units illuminate.

874832

4.10 Master-slave Parallel Operation

4.10.1 Master-slave Parallel Operation (Without Crowbar)

Two or three units of power supplies connected in parallel can be operated in a master-slave mode, operating one unit as a master and other units (up to units) as slaves.

PRECAUTIONS: This mode of operation can be made only with the same model of power supplies.

For this mode of operation, proceed as follows:

- (1) Turn off the POWER switches.
- (2) Connect terminal ⑥ of the rear terminal block of the master unit to terminal ④ of the rear terminal block of each slave unit. (Disconnect the jumper from between terminals ④ and ⑤ of each slave unit.)
- (3) When the wiring distance to the load is longer than 2 meters, make the wiring distance between two units as short as possible (should be less than 2 meters).
- (4) Connect the output terminals of all units to the load using cables of the same gauge and same length. (Note that, of the PAK Series Power Supplies, if the gauges or lengths of the cables used for wiring of the ⊖ OUTPUT terminals differ (or more accurately, if the differential potentials of the ⊖ OUTPUT terminals with respect to the potential of the ⊖ terminal of the load differ), the currents delivered by individual units will become ununiform. $L1=L2=L3$)
- (5) Set the SW2 switch of the rear panel of each slave unit to REM-1.
- (6) Set the SW4 switch of the rear panel of each slave unit to R3.
- (7) Set the 7th element of SW5 on the rear panel of each slave unit to the OFF state. (See Figure 4-2.)
- (8) Connect in parallel the DIN connector (J1) pins 5 of all units as shown in Figure 4-15.

- (9) Connect in parallel the DIN connector (J1) pins 6 of all units as shown in Figure 4-15.
- (10) Connect in parallel the terminals ⑦ of the rear terminal blocks of all units as shown in Figure 4-15.
- (11) Connect in parallel the ⊕ terminals of the rear terminal blocks of all units as shown in Figure 4-15.
- (12) Connect the DIN connector (J1) pin 5 of the master unit to the ⊕ terminal of the rear terminal block.
- (13) Connect the DIN connector (J1) pin 6 of the master unit to terminal ⑦ of the rear terminal block.
- (14) Turn fully counterclockwise the voltage setting knob of each slave unit.
- (15) For the remote sensing mode or the remote control mode of operation, control the master unit alone.
- (16) For the remote sensing mode of operation, connect in parallel the ⊕ and ⊕ terminals of units and disconnect their jumper wires from between terminals ⊕ and ⊕ and between ⊕ and ⊖ terminals.
- (17) Regarding the switches for which no settings are specified in Figure 4-15, set them to the standard states as shown in Figure 2-25 (See Section 2.4.) or to appropriate states for respective modes (See Sections 4.1 through 4.11.).

- Notes:
1. The output mode is indicated by the C.V and C.C lamps of the master unit. Of each slave unit, the C.C lamp illuminates constantly.
 2. For the cables for wiring to the load, refer to Table 2-1 of Section 2.1.8.
 3. Connect the GND terminal to the ⊕ or ⊖ terminal unless there is any particular reason for connecting otherwise.
 4. When the OVP feature is to be employed, OVP trip voltage setting must be done for all of the individual units.
 5. For connect the ⊕ terminal of master unit to the ⊕ terminal of all slave units, use a shielded cable and connect the shielding wire to the ⊖ terminal of the power supply.

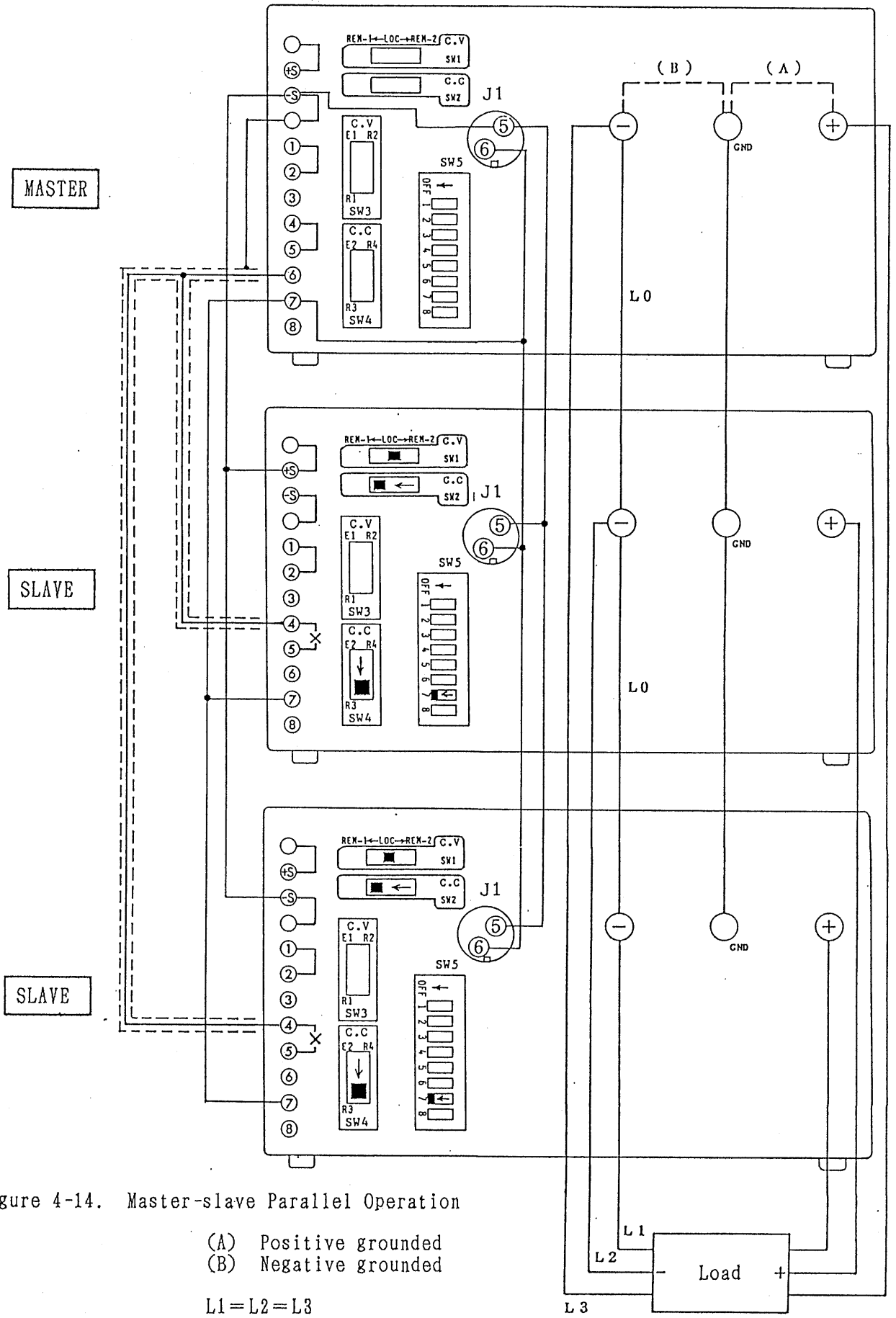

Figure 4-14. Master-slave Parallel Operation

- (A) Positive grounded
- (B) Negative grounded

$L1 = L2 = L3$
 If $L1 > 2m$, $L0 \leq 2m$

共面

874835

26

4.10.2 Master-slave Parallel Operation (with Crowbar)

Two or more units of the same model of power supplies of the PAK Series connected in parallel can be operated in a master-slave mode, with their high speed thyristor crowbar OVP function set in the abled state.

(When operating different models of power supplies connected in parallel, disable the crowbar OVP function.)

For this mode of operation, proceed as follows:

- (1) Turn off the POWER switches.
- (2) Connect terminal ⑥ of the rear terminal block of the master unit to terminal ④ of the slave unit.
- (3) Connect the output terminals of all units to the load using cables of the same gauge and same length. (Note that, of the PAK Series Power Supplies, if the gauges or lengths of the cables used for wiring of the ⊖ OUTPUT terminals differ (or more accurately, if the differential potentials of the ⊖ OUTPUT terminals with respect to the potential of the ⊖ terminal of the load differ), the currents delivered by individual units will become ununiform.)
- (4) Set the SW2 switch of the rear panel of each slave unit to REM-1.
- (5) Set the SW4 switch of each slave unit to E2 • R4.
- (6) Set the 7th element of SW5 on the rear panel of each slave unit to the OFF state. (See Figure 4-2.)
- (7) Set the 2nd element of SW5 of the rear panels of all units to the OFF state. (See Figure 4-2. Refer to Section 4.3.)
- (8) Set the 4th element of SW5 on the rear panels of all units to the ON state. (See figure 4-2. Refer to Section 4.4.)
- (9) Set the 5nd element of SW5 of the rear panels of all units to the ON state. (See Figure 4-2. Refer to Section 4.5.)
- (10) Set the 6th element of SW5 on the rear panels of all units to the OFF state. (See figure 4-2. Refer to Section 2.5.)
- (11) Connect in parallel the DIN connector (J1) pins 5 of all units as shown in Figure 4-15.
- (12) Connect in parallel the DIN connector (J1) pins 6 of all units as shown in Figure 4-15.

- (13) Connect in parallel the terminals ⑧ of the rear terminal blocks of all units as shown in Figure 4-15.
- (14) Connect in parallel the ⑨ terminals of the rear terminal blocks of all units as shown in Figure 4-15.
- (15) Connect the DIN connector (J1) pin 5 of the master unit to the ⑩ terminal of the rear terminal block.
- (16) Connect the DIN connector (J1) pin 6 of the master unit to terminal ⑪ of the rear terminal block.
- (17) Turn fully clockwise the voltage getting knob of each slave unit.
- (18) For the remote control mode of operation, control the master unit alone.
- (19) For the remote sensing mode of operation, connect in parallel the ⑫ and ⑬ terminals of units and disconnect their jumper wires from between terminals ⑭ and ⑮ and between ⑯ and ⑰ terminals.
- (20) Regarding the switches for which no settings are specified in Figure 4-15, set them to the standard states as shown in Figure 2-25 (See Section 2.4.) or to appropriate states for respective modes (See Sections 4.1 through 4.11.).

- Notes:
1. Be sure to turn on the POWER switches of all units when in this mode of operation.
 2. Set the OVP trip voltage on of the master unit alone.
 3. The output mode is indicated by the C.V and C.C lamps of the masterunit.
 4. Of the slave units, the CC lamps illuminate constantly.
 5. For the cables for wiring to the load, refer to Table 2-1 of Section 2.8.1.
 6. Connect the GND terminal to the ⑱ or ⑲ terminal unless there is any particular reason for connecting otherwise.
 7. For connect the ⑳ terminal of master unit to the ㉑ terminal of all slave units, use a shielded cable and connect the shielding wire to the ㉒ terminal of the power supply.

874837

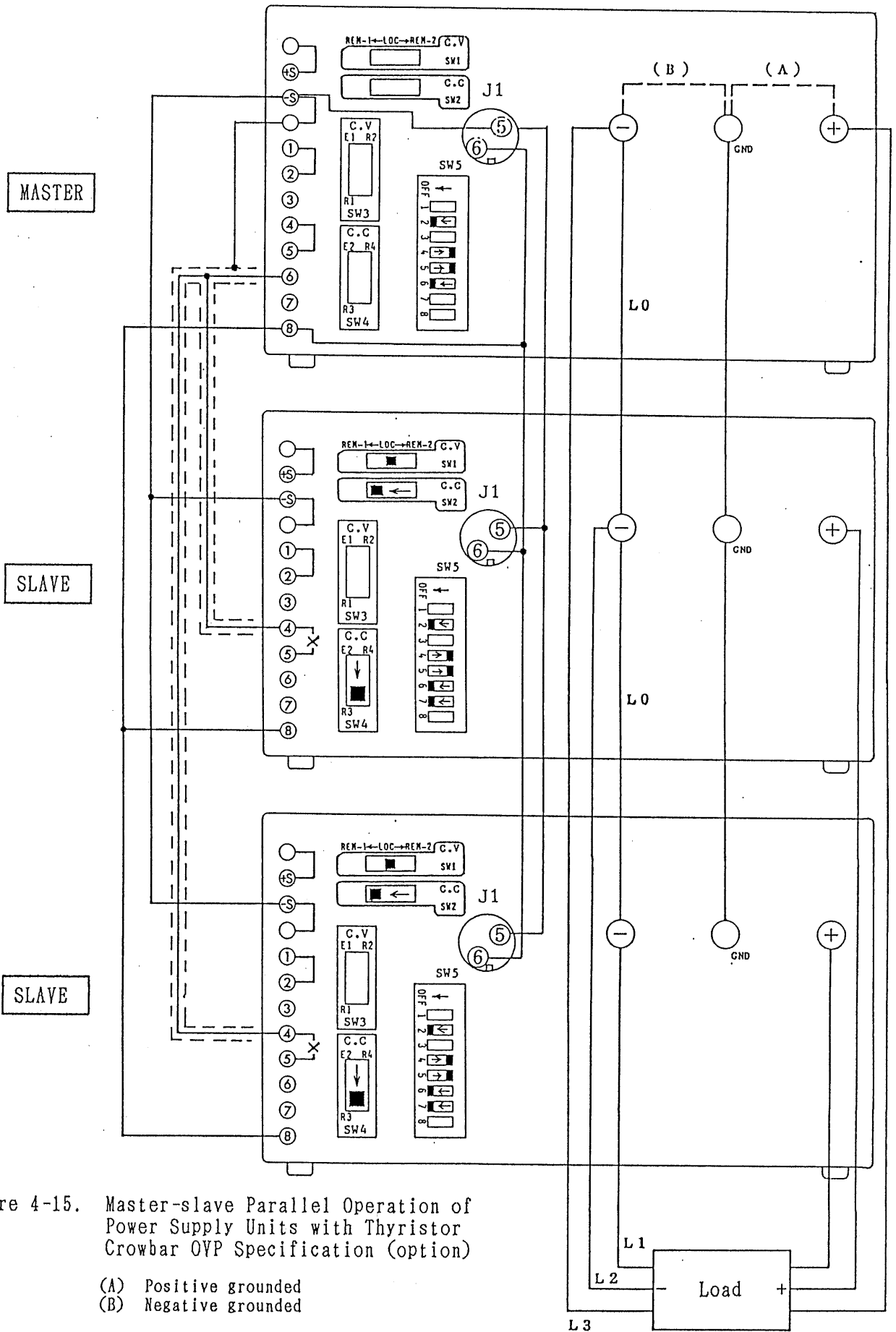

Figure 4-15. Master-slave Parallel Operation of Power Supply Units with Thyristor Crowbar OVP Specification (option)

- (A) Positive grounded
- (B) Negative grounded

$L1=L2=L3$
If $L1 > 2m$, $L0 \leq 2m$

874838

29

4.11 Master-slave Series Operation

Two or more units of power supplies connected in series can be operated in a master-slave mode, operating one unit as a master and other units as slaves, to attain a higher output voltage. For this setup, proceed as follows:

- (1) Turn off the POWER switches.
- (2) Referring to Figure 4-5, the bottom unit is the master and all upper units are slaves.
- (3) Connect resistor R5 (R6) between terminal 1 of the rear terminal block of each slave unit and the \oplus terminal of that of the unit below the above unit as shown in Figure 4-5.
- (4) Connect in series the outputs of all units.
- (5) Connect together the GND terminals of all units, and connect it to a line of the voltage you may require.
- (6) Turn fully clockwise the current setting knob of each slave unit.
- (7) Throw the SW1 switch of the rear panel of each slave unit to the REM-1 position.
- (8) Throw the SW3 switch of the rear panel of each slave unit to the R1 position.
- (9) Set the 8th element of SW5 of the rear panel to the OFF state.
- (10) Regarding the switches for which no settings are specified in Figure 4-16, set them to the standard states as shown in Figure 2-25 (See Section 2.4.) or to appropriate states for respective modes (See Sections 4.1 through 4.11.).

To determine the resistance of external resistor R5 (R6), use the following formula:

$$R5 = \left(\frac{E1}{E2} \times A \right) - B \text{ [k}\Omega\text{]}$$

where, E1: Output voltage of master unit [V]

E2: Output voltage of slave unit 1 [V]

R5 [kΩ] ≥ 0

$$E2 \leq \left(\frac{A}{B} \cdot E1 \right)$$

$$R6 = \left(\frac{E2}{E3} \times A \right) - B \text{ [k}\Omega\text{]}$$

where, E2: Output voltage of slave unit 1 [V]

E3: Output voltage of slave unit 2 [V]

R6 [kΩ] ≥ 0

$$E3 \leq \left(\frac{A}{B} \cdot E2 \right)$$

For resistor R5 and R6, use a quality resistor of 1/2 watt or more and with a good temperature coefficient and good aging and noise characteristics.

The values of A and B are as shown in Table 4-5.

Table 4-5

Model		PAK10-200T	PAK20-100T		
A [kΩ]		100	200		
B [kΩ]		100	100		

8748210

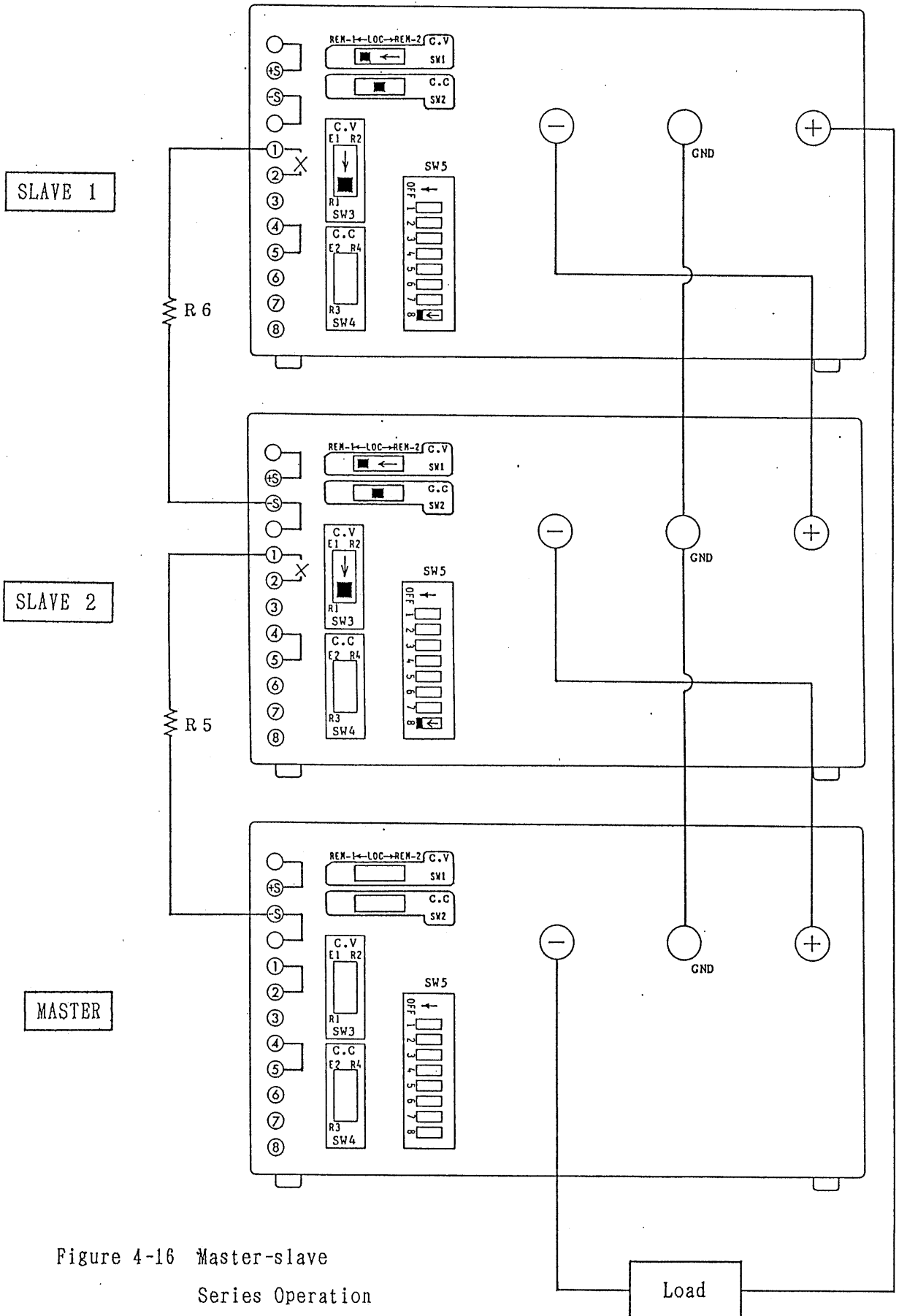

Figure 4-16 Master-slave
Series Operation

874841

112

4.12 Constant-current Charge/Discharge

4.12.1 Constant-current Charge

The power supply can be used to charge a battery or a capacitor with a constant current. For this type of use, refer to Figure 4-17 and proceed as below.

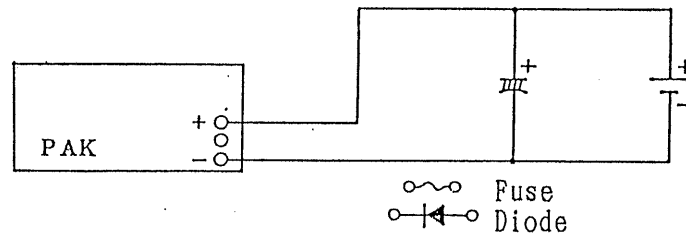

Figure 4-17

- (1) For select the regular OVP mode, set the 5th element of SW5 to the ON state. (Refer to Section 4.5.)
- (2) By pressing the current/voltage limit switch, set the charging current with the current setting knob and the charge-end voltage with the voltage setting knob.
- (3) Connect the power supply output terminals to the battery terminals in the correct polarity.

PRECAUTIONS: Note that the reverse connection protector diode built in the power supply may be damaged if they are connected in the wrong polarity. (Although the diode protects the power supply itself, the load may remain shorted and this is dangerous. It is most recommendable to connect externally a series diode or a fuse in order to protect the equipment against reverse polarity connection.)

874842

- (4) Turn on the OUTPUT switch. The power supply will start charging the load with the constant current and, when the load is charged up to the charge end voltage, the power supply will automatically transfer itself into the constant-voltage mode to stop charging the load.

- Notes:
1. The power supply has a potentiometer burn protect circuit and the voltage setting potentiometer can be safely set at a voltage lower than the voltage of the load (battery or capacitor).
 2. At the instant you connect the power supply to the load (battery or capacitor), sparks may be produced. These are not abnormal sings. They are caused as the load charges the output capacitor of the power supply. They can be eliminated by setting the power supply output voltage at a level close to the voltage of the load before connection.
 3. If you leave the load (battery or capacitor) connected to the power supply, a current of several handreds milli-amperes will be drawn by the discharge circuit of the power supply from the load. When this discharge current is not tolerable, connect a switch or a diode in the output circuit.
 4. Keep the crowbar switch in the OFF state. (To operate the power supply with its crowbar switch set in the ON state, connect a check diode in series to the power supply.)

874843

4.12.2 Constant-current Discharge

The power supply can be used to discharge a battery with a constant current.

For this type of use, refer to Figure 4-18 and proceed as below.

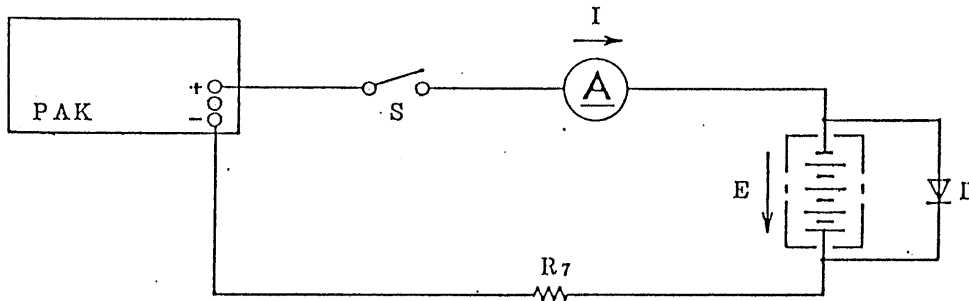

Figure 4-18

E: Battery terminal voltage [V] before starting discharge

I: Constant discharge current [A]

R7: Discharge load resistor $R7 [\Omega] = \frac{E [V]}{I [A]}$

D: Reverse charge current check diode

Power consumption by R7: $P = I^2 \cdot R [W]$

- (1) Set the output voltage at a level higher by several volts than that of the battery voltage. (With this setting, the battery can be discharged with a constant current until it becomes zero volts.)
- (2) Calculate the resistance and wattage of the discharge load resistor (R7). Use a load resistor which has a sufficient wattage allowance.
- (3) Press the current/voltage limit switch. Set the discharge current with the current setting knob of the power supply.
- (4) Turn on the OUTPUT switch of the power supply and the external limit switch (S). The constant-current discharge will start.

874844

(5) To stop discharging, open the external limit switch(S). (Even when the POWER switch or OUTPUT switch of the power supply is turned off, the discharge current wil continue flowing through the diode connected in parallel to the output circuit of the power supply.)

- PRECAUTIONS:
1. Be sure to use an external load resistor (R7) when discharging the load. Note that the power supply may be damaged if the load (battery) is directly connected to the power supply.
 2. Be sure to provide a reverse charge current check diode (D).

874845

5. MAINTENANCE

5.1 Inspection

Inspect and clean the power supply for any signs of abnormality, periodically at appropriate intervals.

5.1.1 Cleaning of Outside

When the external surfaces of the power supply have become dirty, clean them using a cloth moistened with neutral soap or alcohol and then wipe them with a dry cloth.

5.1.2 Cleaning of Air Intake Filter

The air intake filter is located inside of the air intake louver (see Figure 2-17). Clean the filter periodically—once at every 2 months or thereabout. When environments are dusty, clean it more often. Use neutral soap when the filter is heavily stained.

5.1.3 Cleaning of Inside

Clean periodically the inside of the power supply after removing its covers. To remove the covers, remove the screws shown in Figure 5-1.

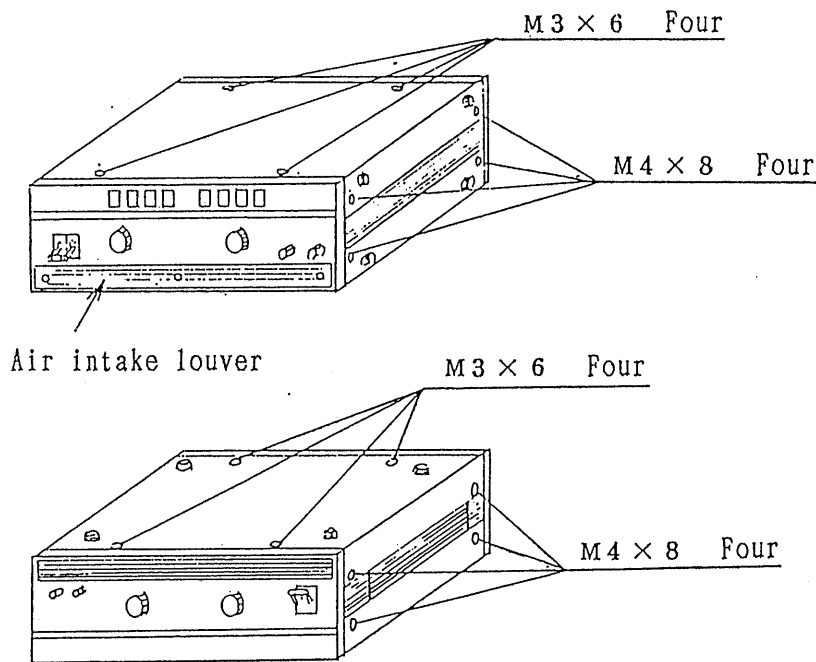

Figure 5-1

- Notes:
1. Be sure to disconnect the input power cord from the line receptacle for the sake of safety.
 2. To clean the equipment inside, blow it with a dry and clean compressed air.

- WARNINGS:
1. Do not attempt to open the shielding case inside the equipment. The components protected in the shielding cases must be serviced only by the agents authorized by Kikusui.
 2. Do not disturb the setting of the switches which are not referred to in this manual.

5.1.4 Inspection of Power Cord

Inspect the power cord for loose screws, loose terminals, and any signs of overheat or damage.

5.2 Adjustment and Calibration

5.2.1 Calibration of Maximum Variable Range of Output Voltage

5.2.1.1 Calibration for Voltage Setting Knob of Front Panel (See Figure 2-3.)

Connect to the output a voltmeter of an accuracy of 0.5% or better. Adjust VR4 of PCB A-700 so that the correct output voltage as shown in Table 5-1 is delivered when the voltage setting knob is turned to the clockwise extreme position.

5.2.1.2 Calibration for Remote Control Signal

Disconnect the jumper from between terminals ① and ② of the rear terminal block. Short between terminals ① and ⑤ of the rear panel, throw the SW1

of the rear panel to the REM-1 position (see Section 2.3) and the SW3 switch to the E1 position. Turn on the POWER switch and adjust the V.os control of the service panel so that the potential of TP16 of PCB A-700 becomes zero volts with respect to that of T.P A.COM when the POWER switch is turned on. Turn off the POWER switch and set the SW1 switch to the LOC position. Connect to the output circuit a voltmeter of an accuracy of 0.5% or better. Turn on the POWER switch and adjust RV3 of PCB A-700 so that the potential of TP18 of PCB A-700 becomes +10 volts with respect to that of the Ⓢ terminal. Next, adjust RV4 of PCB A-700 so that the output voltage as shown in Table 5-1 is delivered when a remote control voltage signal of 10 volts (see Section 4.7.1) or a remote control resistance signal of 10 k Ω (see Section 4.7.2) is applied.

5.2.2 Calibration of Voltage Limit Switch

Set the output voltage at zero volts. Adjust the VL.os control of the service panel so that the voltmeter reads zero volts when the current/voltage limit switch is pressed. Set the output at the value shown in Table 5-1 and adjust the VL.FS control of the service panel so that the same value is read when the current/voltage limit switch is pressed.

5.2.3 Calibration of Voltmeter

Connect to the output circuit a voltmeter of an accuracy of 0.5% or better. Set the output voltage at the value shown in Table 5-1 and adjust the V.FS control of the service panel so that the panel voltmeter reads the same value.

5.2.4 Calibration of OVP Trip Voltage

Set the output voltage at the value shown in Table 5-1. Gradually turn counterclockwise the OVP setting control of the front panel with a screwdriver to the point where the OVP circuit trips. Set the output voltage at a value slightly higher than the voltage at which the OVP circuit has tripped. Turn on the POWER switch and adjust RV13 of PCB A-700 so that the value indicated when the OVP switch is pressed becomes the value shown in Table 5-1.

5.2.5 Calibration of Maximum Variable Range of Output Current

5.2.5.1 Calibration for Current Setting Knob of Front Panel (See Section 2.2)

Connect in the output circuit an ammeter of accuracy 0.5% or better. Turn the current setting knob to the clockwise extreme position and adjust RV7 of PCB A-700 so that the output current as shown in Table 5-1 is delivered.

5.2.5.2 Calibration for Remote Control Signal

Disconnect the jumper from between terminals ④ and ⑤ of the rear terminal block. Short between terminals ④ and ⑤ of the rear panel, throw the SW2 of the rear panel to the REM-1 position (see Section 2.3) and the SW4 switch to the E2 position. Turn on the POWER switch and adjust the I.os control of the service panel so that the potential of TP17 of PCB A-700 becomes zero volts with respect to that of T.P A.COM when the POWER switch is turned on. Turn off the POWER switch and set the SW2 switch to the LOC position. Connect to the output circuit an ammeter of an accuracy of 0.5% or better. Turn on the POWER switch and adjust RV3 of PCB A-700 so that the potential of TP18 of PCB A-700 becomes +10 volts with respect to that of the ⑤ terminal. Next, adjust RV6 of PCB A-700 so that the output current as shown in Table 5-1 is delivered when a remote control voltage signal of 10 volts (see Section 4.8.1) or a remote control resistance signal of 10 k Ω (see Section 4.8.2) is applied.

5.2.6 Calibration of Current Limit Switch

Set the output current at zero amperes. Adjust the AL.os control of the service panel so that the ammeter reads zero amperes when the current/voltage limit switch is pressed. Next, set the output current at the value shown in Table 5-1. Adjust the AL.Fs control of the service panel so that the output current becomes the value shown in Table 5-1 when the current/voltage limit switch is pressed.

5.2.7 Calibration of Ammeter

Connect in the output circuit an ammeter of accuracy 0.5% or better. Set the output current at the value shown in Table 5-1 and adjust the A.Fs control of the service panel so that the panel ammeter also reads the value shown in Table 5-1.

Table 5-1

Model	PAK10-200T	PAK20-100T	
Rated output voltage	10.0 V	20.0 V	
Maximum variable range of constant-voltage output	10.5 V	21.0 V	
Calibration of voltage limit switch	10.0 V	20.0 V	
Calibration of voltmeter	10.0 V	20.0 V	
Calibration of OVP trip voltage	10.0 V	20.0 V	
Rated output current	200 A	100 A	
Maximum variable range of constant-current output	210 A	105 A	
Calibration of current limit switch	200 A	100 A	
Calibration of ammeter	200 A	100 A	

REPAIR OF THE POWER SUPPLY

When the power supply has failed, order your Kikusui agent for repair. As a general rule, the power supply should be serviced by the agents authorized by Kikusui.

Never attempt to open the shielding cases of the internal components of the power supply. If these components are attempted to be repaired or otherwise disturbed, Kikusui may not accept repair order of such power supply.

87.8.3

874850A

874851

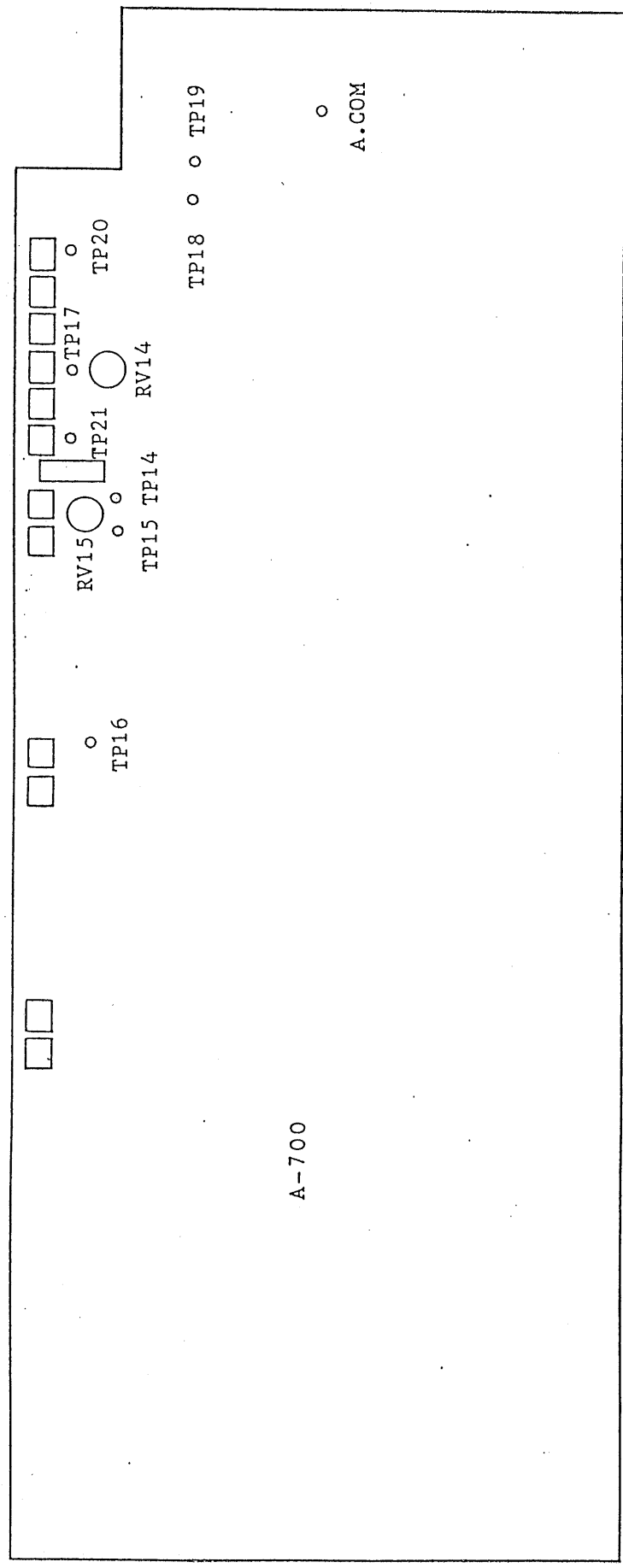

Figure 5-2. Layout of Controls on PCB A-700

6